

Canon

PJ-1080A

Color Ink-Jet Printer



OPERATION MANUAL

FOREWORD

The Canon Ink-Jet Printer is a terminal printer for personal computers that is easy to operate yet capable of producing printouts in seven vivid colors.

The Canon Ink-Jet Printer has many excellent features, but its main feature is the capping mechanism with completely sealed ink supply operation. Capping prevents the ink from drying out and dust particles from clogging up the nozzles, giving you clear color printouts. Should you ever have a printing problem, the pumping mechanism lets you rectify the problem with a touch of the green lever.

For office or home use, the Canon Ink-Jet Printer not only prints information from the computer clearly and accurately, but it also lets you be more creative.

To ensure long, trouble-free operation of the printer, read this manual carefully, and keep it handy for future reference.

TABLE OF CONTENTS

GENERAL

1. THE PJ-1080A COLOR INK-JET PRINTER	2
1.1 Color Printing	2
1.2 Printing Modes	3
1.2.1 Text Mode	3
1.2.2 Graphic Image Mode	3
1.2.3 Color Graphic Image Mode	3
1.3 What Is an Ink-jet Printer?	4
1.3.1 Various Printing Methods	4
1.3.2 Ink-on-demand Method	4
1.4 Ink Supply Mechanism	5
1.5 Capping Mechanism	6
1.6 Pumping Mechanism	6
2. PRECAUTIONS	7
2.1 Power Source	7
2.2 Operating Environment	8
3. COMPONENTS	10

HARDWARE

1. CONTROLS AND FUNCTIONS	12
1.1 Overview	12
1.2 Controls and Functions	13
1.2.1 Power Switch	13
1.2.2 Control Panel	13
2. CONNECTING TO YOUR COMPUTER	14
2.1 Connecting the Ground Cable	14
2.2 Connecting the Interface Cable	15
2.3 Connecting the Power Cord	15
3. LOADING FORMS	16
3.1 Loading Roll Paper	16
3.2 Loading Cut Sheets	17
3.3 Loading Overhead Projection Film	18
4. BEFORE PRINTING	19
4.1 Power On/Off Procedure	19
4.2 Unlocking the Carriage	20
4.3 Printing Check	21

4.4 Ink Supply Pumping Operation	22
4.5 Locking the Carriage	23
5. CHANGING INK CARTRIDGES	24
5.1 Checking Ink Levels	25
5.2 Loading Ink Cartridges	26
6. FUNCTIONS	27
6.1 No-paper Error Detection Function	27
6.2 Self-test Function	27
6.3 Bold Print Function	29
6.4 The DIP Switch	29
7. INTERFACE SPECIFICATIONS	31

SOFTWARE

1. BASIC CONTROL CODES	36
1.1 Printing Movements	36
CR Carriage Return—Printing and Carriage Return	36
CAN Cancelling Print Buffer	37
1.2 Line Feed	38
LF Line feed	38
ESC "0" 1/8-inch Line Spacing	39
ESC "2" 1/6-inch Line Spacing	40
1.3 Form Format	41
ESC "C"+0+n Page Length by Inches	41
ESC "C"+n Page Length by Lines	43
FF Form Feed	45
1.4 Perforation Skip	46
ESC "N"+n Perforation Skip	46
ESC "O" Cancelling Perforation Skip	49
1.5 Tabs	50
ESC "D"+n ₁ +n ₂ +...+n _k +0 Setting Horizontal Tab Positions	50
HT Executing Horizontal Tabs	51
ESC "B"+n ₁ +n ₂ +...+n _k +0 Setting Vertical Tab Positions	53
VT Executing Vertical Tabs	54
2. COLOR CONTROL CODES	57
ESC "V"+n Setting Character Colors	57
ESC "g"+n Setting Background Colors	59
3. CHARACTER DESIGN CONTROL CODES	63
ESC "d"+n Solarized Mode	63
SO Shift Out—Setting Enlarged Mode with Automatic Self-Cancellation	65
ESC SO Setting Enlarged Mode with Automatic Self-Cancellation	67
DC4 Device Control 4—Cancelling Enlarged Mode with Automatic Self-Cancellation	69
ESC "W"+n Setting Enlarged Mode	70
ESC "!" +n Setting Enlarged Mode	71

ESC "G" Setting Bold Mode	72
ESC "H" Cancelling Bold Mode	75
ESC "-" + n Setting Underlined Mode	76
4. GRAPHIC IMAGE CONTROL CODES	78
ESC "K" + n ₁ + n ₂ Setting Graphic Image Mode	78
ESC "*" + m + n ₁ + n ₂ Setting Graphic Image Mode	82
5. COLOR GRAPHIC IMAGE CONTROL CODES	84
ESC "X" + n Setting Color Graphic Image Mode	84
ESC "r" + n ₁ + n ₂ Executing Color Graphic Image Repeat	89
ESC "e" + n Executing Color Graphic Image Dot Line Skip	91
6. OTHER CONTROL CODES	93
ESC "@" Printer Reset	93
DC1 Printer Select	94
DC3 Printer Deselect	95

APPENDICES

1. TRANSPORTATION AND STORAGE	98
1.1 Transportation	98
1.2 Storage	100
2. TROUBLESHOOTING	101
3. HARDWARE SPECIFICATIONS	102
4. CHARACTER CODE TABLE	104
4.1 U.S.A.	104
4.2 France	105
4.3 Germany	106
4.4 U.K.	107
4.5 Denmark	108
4.6 Sweden	109
4.7 Italy	110
4.8 Japan	111
5. INTERNATIONAL CHARACTER CODE TABLE	112
6. APPLICATION PROGRAMS AND PRINTOUTS	113
7. CONTROL CODE LIST	123
7.1 Basic Codes	123
7.2 Expanded Codes	123

GENERAL

This chapter describes the mechanism of the ink-jet printing system, and precautions on operating the printer.

1. THE PJ-1080A COLOR INK-JET PRINTER

1.1 Color Printing

This printer can print in seven colors: four primary (yellow, magenta, cyan and black) and three composite (red, green and blue). White areas can also be designated; therefore, you can print in eight different colors.

Primary colors

1. Yellow



2. Magenta



3. Cyan



4. Black



Composite colors

5. Red



6. Green



7. Blue



1.2 Printing Modes

The printer can be used in the following three modes, and each mode can be set by entering its control code.

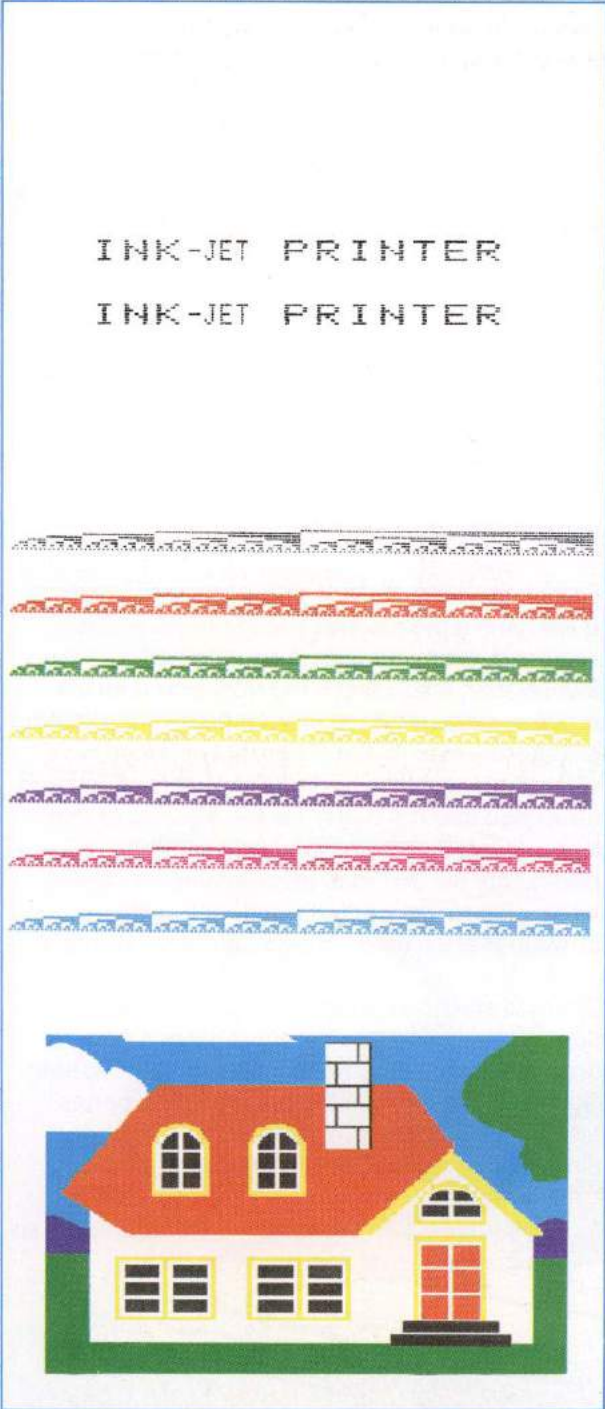

1.2.1 Text Mode

The printer is automatically set to this mode when the power is turned on. Color can be set for each character of the following two groups of characters:

Group	Total number of characters
a. Letters, numbers and symbols	96
b. Special characters	64

- 28 of the above characters can be set for different countries (U.S.A., France, etc.) with a DIP switch.
- Standard and enlarged characters can be printed mixed on one line.

1.2.2 Graphic Image Mode

The printer is set to this mode when the control code "ESC K" is entered. In this mode, a color can be set for every graphic image byte, each of which is created using a set of eight vertical dots.

- Up to 560 graphic image data can be printed on one line.
- The Text mode can be reset at any point.

1.2.3 Color Graphic Image Mode

The printer is set to this mode when the control code "ESC X" is entered. In this mode, up to 80 bytes of data can be output per line. Each byte of data is created using a set of 8 horizontal dots, and a color can be set for each dot, up to 640 dots per line.

1.3 What Is an Ink-jet Printer?

abcdefghijklmnopqrstuvwxyz{|}~&
ABCDEFGHIJKLMNOPQRSTUVWXYZ
ABCDEFGHIJKLMNOPQRSTUVWXYZ
ABCDEFGHIJKLMNOPQRSTUVWXYZ
ABCDEFGHIJKLMNOPQRSTUVWXYZ
ABCDEFGHIJKLMNOPQRSTUVWXYZ

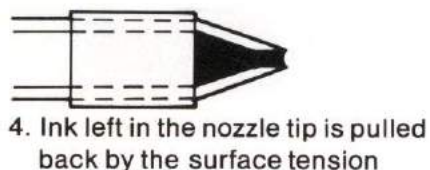
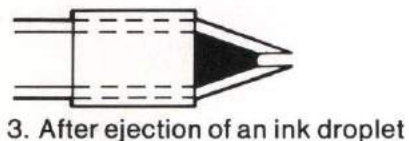
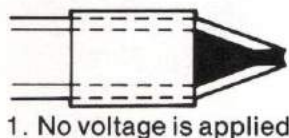
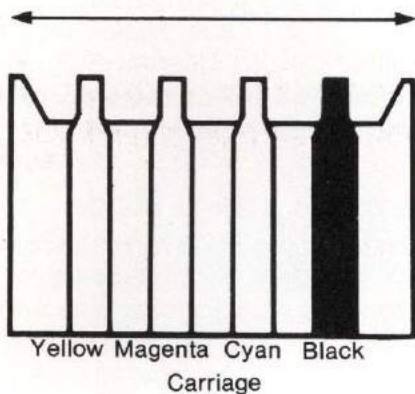

1.3.1 Various Printing Methods

Besides such printing methods as impact ink-ribbon, non-impact thermal (using thermal paper), and pen-plotter printing, there are other printing methods such as the instant photographic and electrophotographic methods. Each method has unique features.

This printer employs the ink-jet method, which is fundamentally different from the above-mentioned methods. In this method, ink droplets are fired like jets from very thin nozzles.

1.3.2 Ink-on-demand Method

As shown in the illustration (top view), the ink-jet nozzles (for the colors yellow, magenta, cyan, and black) are positioned on the carriage linearly in the horizontal direction.

Each nozzle consists of a glass tube 0.1 mm thick, with a piezoelectric transducer wound around it. When voltage is applied to the transducer, it squeezes the nozzle and an ink droplet is ejected from the orifice* by the resulting pressure wave. In other words, one pulse of voltage causes one ink droplet to be ejected and absorbed into the paper for the printing of one dot. Ink-jet printers which print by jetting the necessary ink droplets at the necessary times according to the signals (pulses) from the computer are called "ink-on-demand" printers.

There is also the continuous type, which continuously jets electrically-charged ink droplets and directs them using an electric field. However, the ink-on-demand type has better features, such as no need for high-voltage circuits and refuse ink storage areas.

* Each nozzle's orifice is only 0.065mm wide, so be careful of dust and paper particles.

1.4 Ink Supply Mechanism

The ink supply mechanism is as shown below. A new ink cartridge contains enough yellow, magenta and cyan ink to produce approximately 3.5 million characters, or black ink for approximately 4 million characters. The passage from an ink cartridge to the nozzles is completely sealed, and ink is supplied automatically to each section by capillarity, etc.

The filter removes dirt and air bubbles from the ink, and the air space in the sub-tank acts as a valve to supply ink smoothly to the nozzle from the ink cartridge.

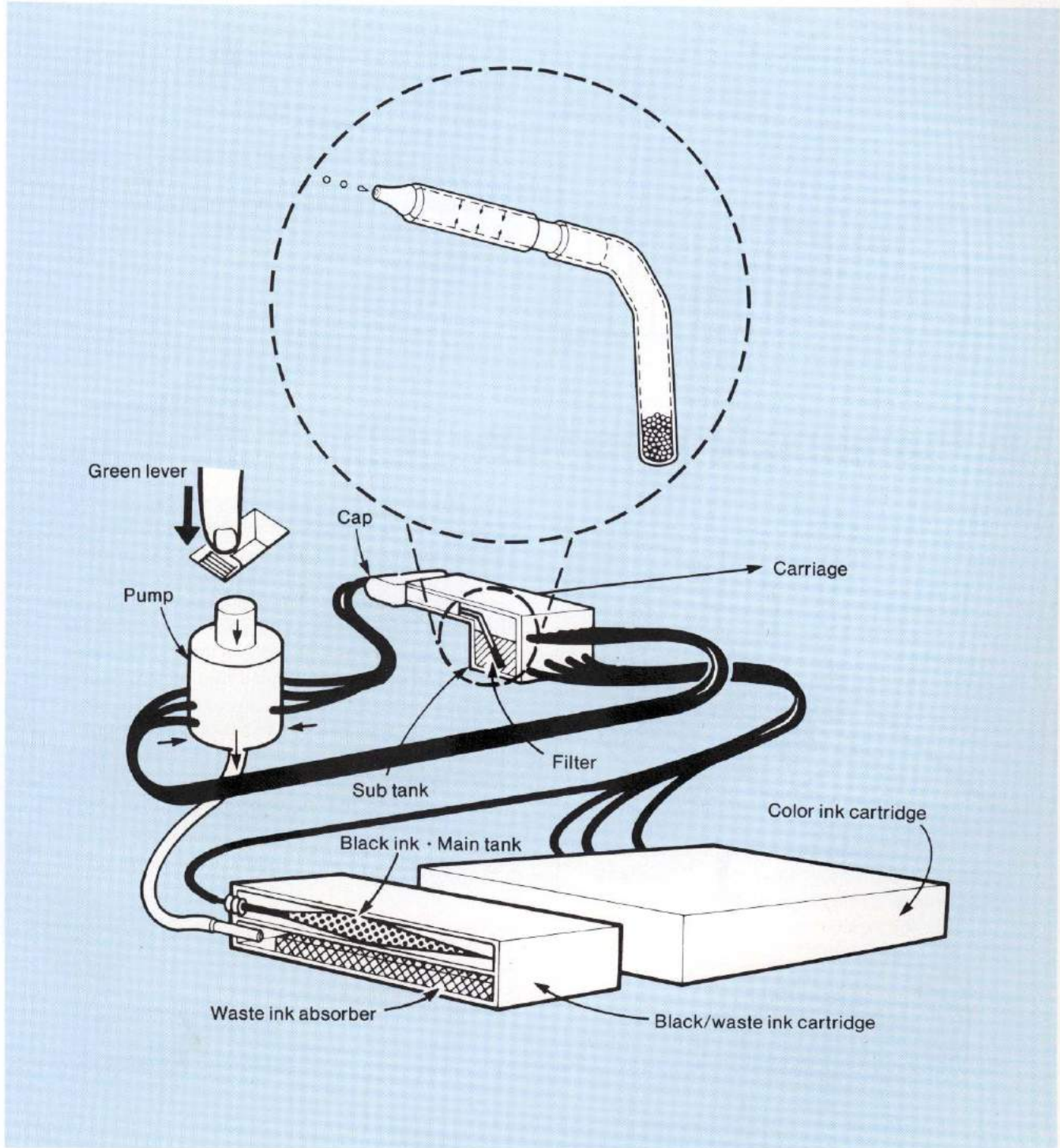

1.5 Capping Mechanism

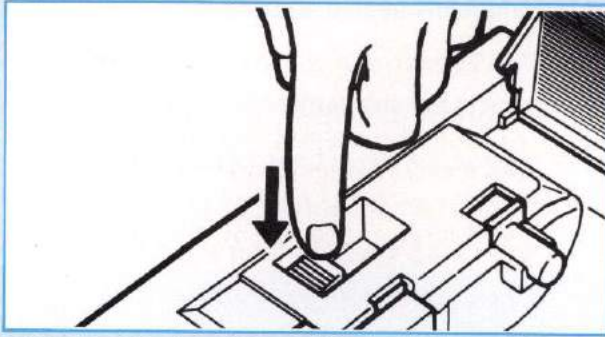

When printing is not being performed, the carriage can be capped by returning it to the home position (extreme left), and then pressing the green lever.* When the carriage is capped, the tip of each nozzle is connected securely to a corresponding ink tube and the ink in the nozzle is able to flow into the tube. Therefore, the ink is completely sealed off from the outside air.

This is referred to as "capping"**. Capping is important since it keeps the ink in the nozzle from drying out and prevents dust from accumulating in the orifices.

Cap

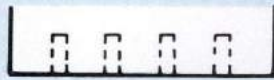

Capping

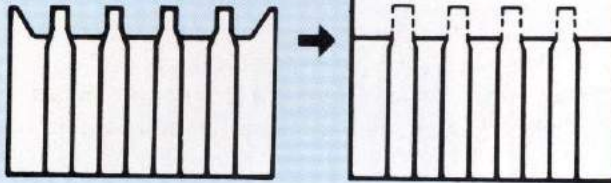

* The carriage is automatically locked when it is capped.

** Capping is necessary only when the printer will not be used for a long time, or when it is being transported.

1.6 Pumping Mechanism

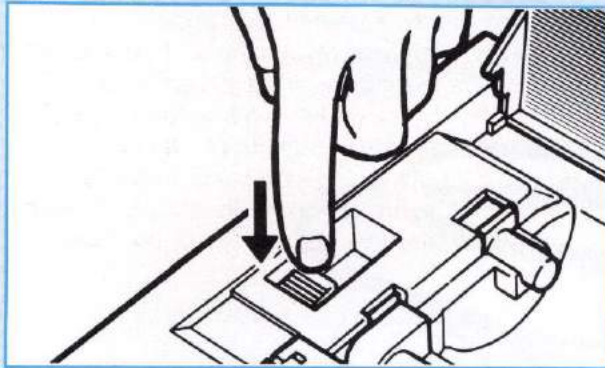

The printer has a specially-designed ink supply mechanism and nozzles that allow it to print in color. However, you will not be able to obtain clear printing when air bubbles have entered the nozzles. This condition can be easily corrected, though, by pressing the green lever all the way down and then releasing it while the carriage is capped. After approximately 10 seconds, air bubbles as well as dust and highly viscous ink are sent to the refuse ink tanks, and the nozzles are filled with fresh ink. Therefore, you can always obtain clear color printing with just a lever operation.

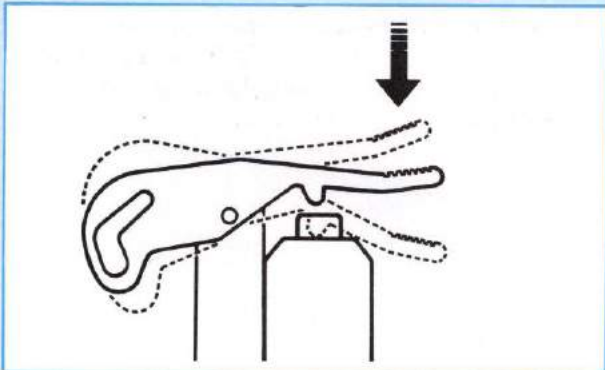

2. PRECAUTIONS

To ensure long, trouble-free operation of the printer, heed the following points:

2.1 Power Source

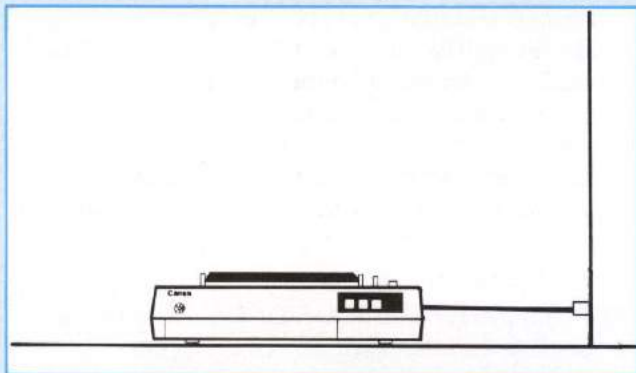

- (1) Use an appropriate power source.
Power source voltage: AC 120V \pm 10%, AC 220/240V \pm 10%
Power source frequency: 50/60 Hz

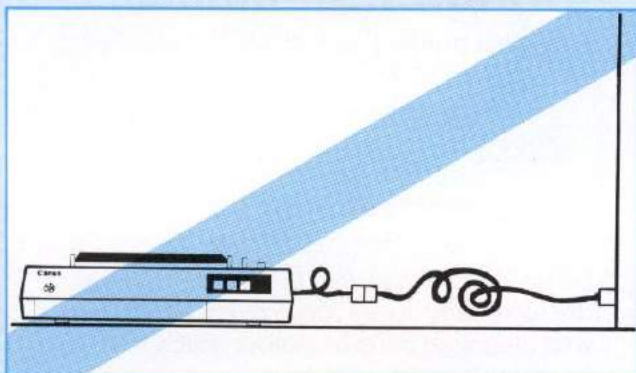

- (2) Be sure that the total power cord length (the power cord plus extension) is not over 5 meters (16.4 feet). Using a longer cord might lower the voltage and cause a malfunction.

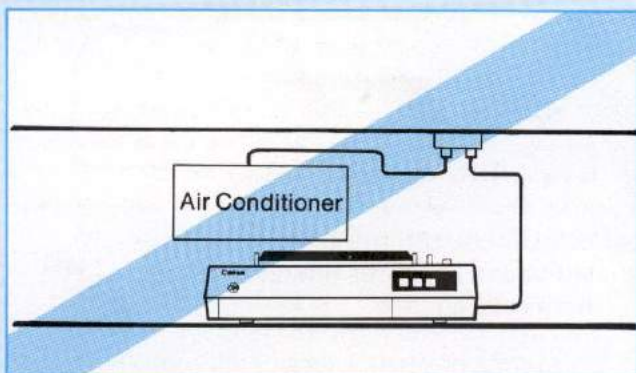

- (3) Do not use the same electric outlet on a circuit supplying power to an air conditioner, fluorescent light, electrostatic copier, or shredder. Noise picked up from this type of equipment might cause the printer to malfunction. If using a common outlet is unavoidable, install an isolation transformer or high-frequency noise-eliminating filter.

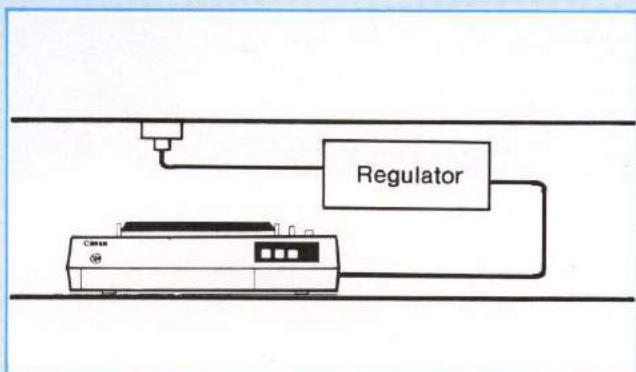

- (4) Use a regulator if the power supply is unstable. Power source equipment such as an automatic voltage regulator is necessary in places where power voltage varies.

2.2 Operating Environment

The operating environment should satisfy the following conditions:

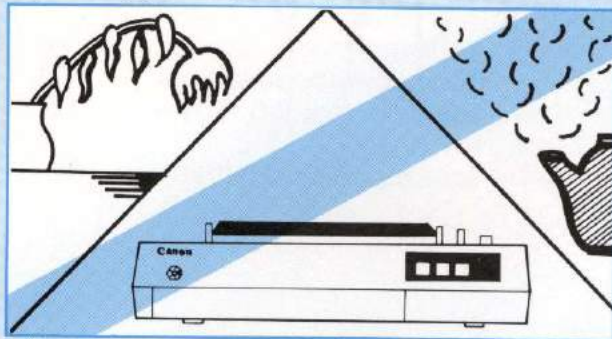

- (1) Use the printer only within the following working ranges of temperature and humidity:
Ambient temperature: 10–35°C
(50°F–95°F)
Ambient humidity: 30–90% (without condensation)
When using the printer in a cold or dry environment, perform the printing check before use. (See Section 6.2)

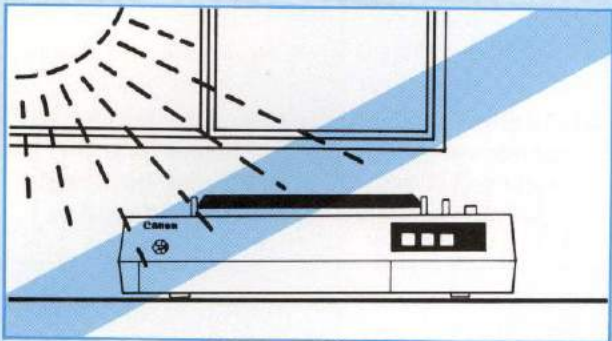

- (2) When using the printer near a window, use a blind or curtain to protect it from direct sunlight. Prolonged exposure to direct sunlight might cause a temperature rise inside the printer and damage delicate parts.

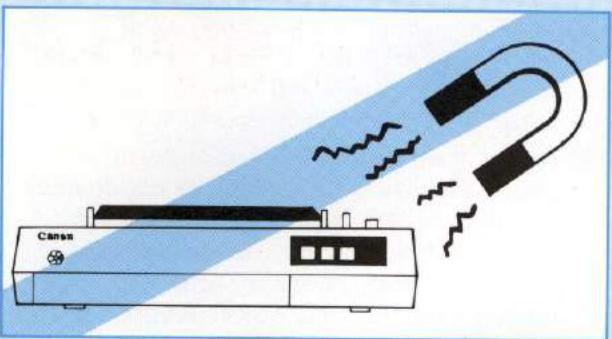

- (3) Do not place the printer in a location where the air is salty. Keep it away from equipment with magnetic parts or motors which generate magnetic fields.

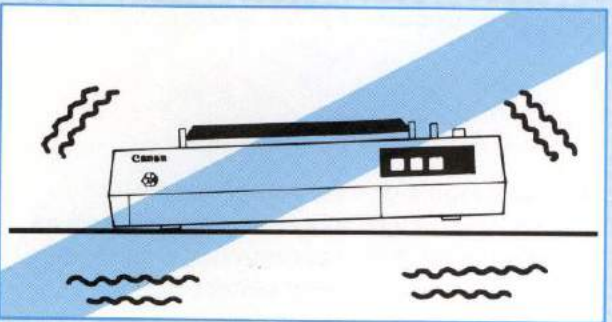

- (4) Do not subject the printer to shocks or vibrations. Place the printer on a flat, horizontal surface.

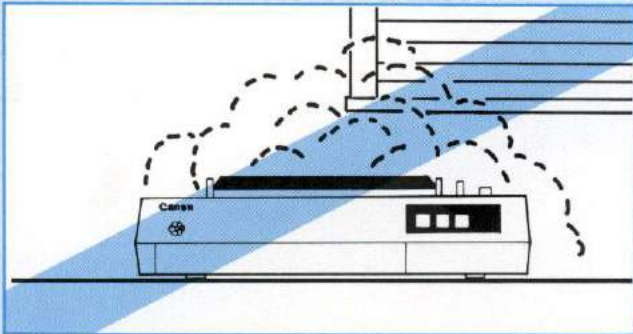

- (5) Keep the printer clean. Dust accumulation can prevent the printer from printing clearly.

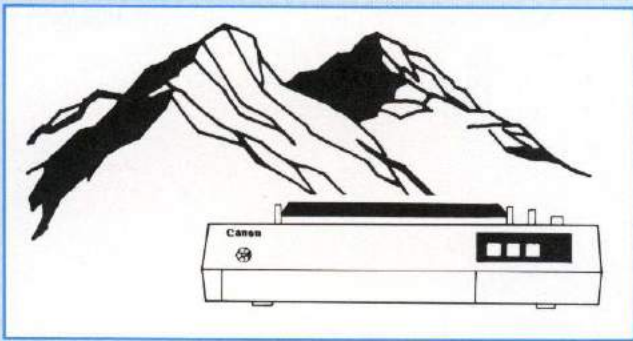

- (6) The printer will not print properly if the air pressure inside the machine differs from the ambient air pressure. (For example, if the printer is moved to a place 1,000 meters above sea level.) In such a case, do not use the printer for approximately one day to allow it to become acclimatized to the new environment.

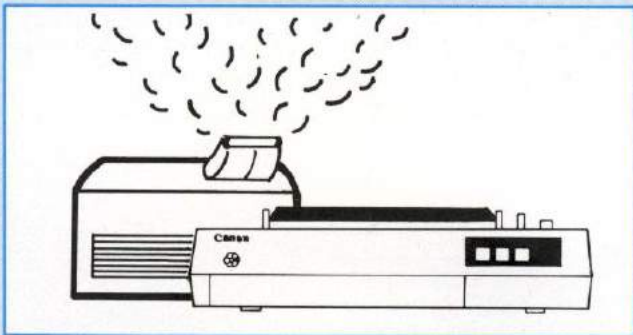

- (7) Use a humidifier or a static electricity protection mat in dry climates. Take special precautions when using the printer in an extremely dry climate (humidity less than 30%).

3. COMPONENTS

Be sure that the following parts are included in the packing box:

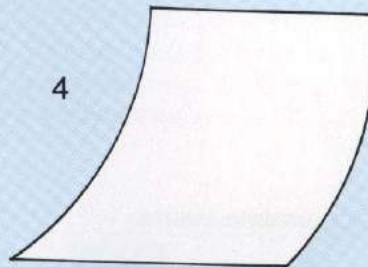
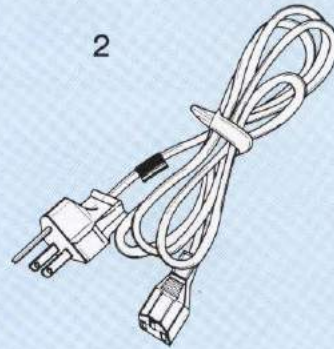
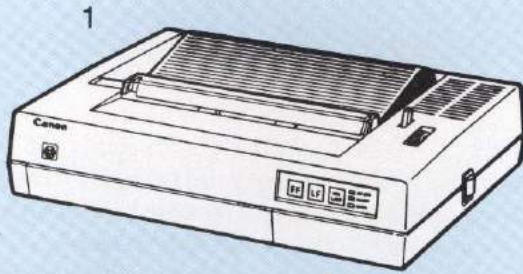

- 1. Ink-Jet Printer
- 2. Power cord
- 3. Operation manual
- 4. Test papers

One black ink cartridge (JI-25B) and one color ink cartridge (JI-20C) are loaded in the printer.

HARDWARE

This chapter explains the type and functions (hardware control) of each part (switches and levers) of the printer and how to set these functions. As "4.2, Unlocking the Carriage", "4.4, Ink Supply Pumping", and "4.5, Locking the Carriage" are of particular importance, be sure to read these sections carefully.

1. CONTROLS AND FUNCTIONS

1.1 Overview

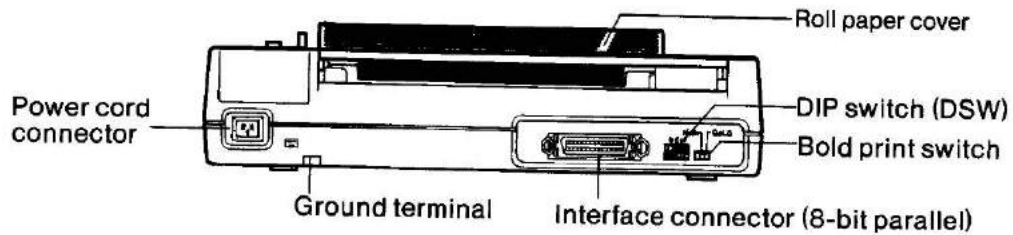
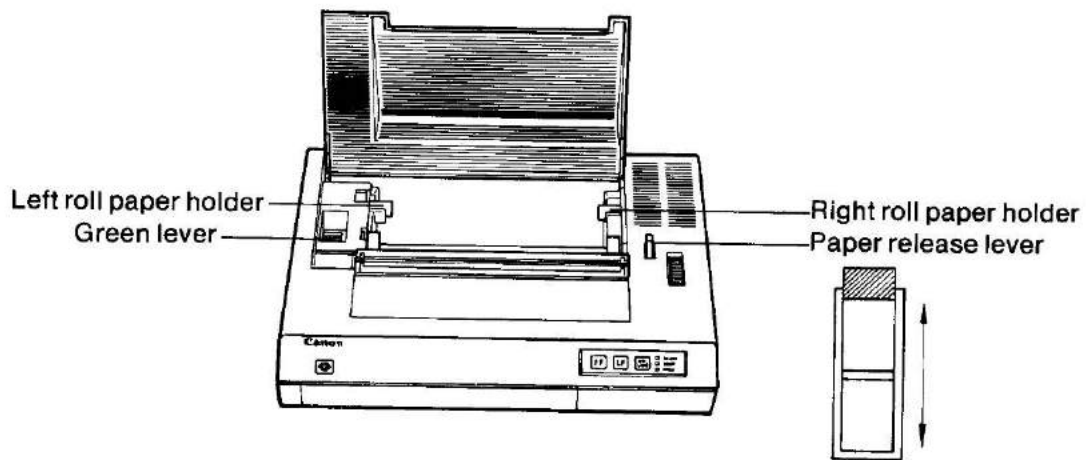
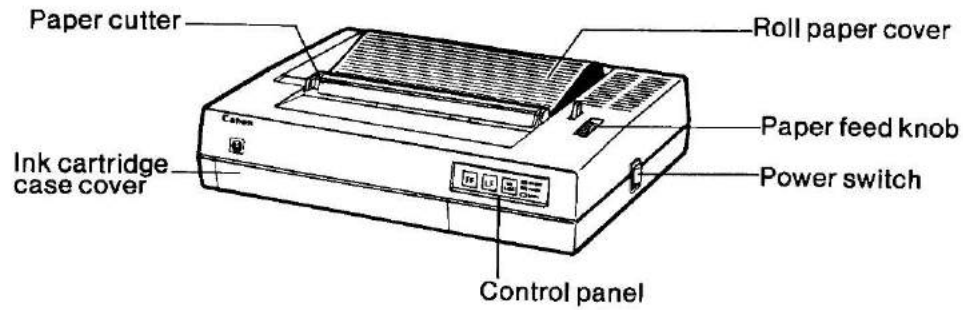

1.2 Controls and Functions

1.2.1 Power Switch

Press the side marked with the red circle to turn the power on.
Press the other side to turn the power off.

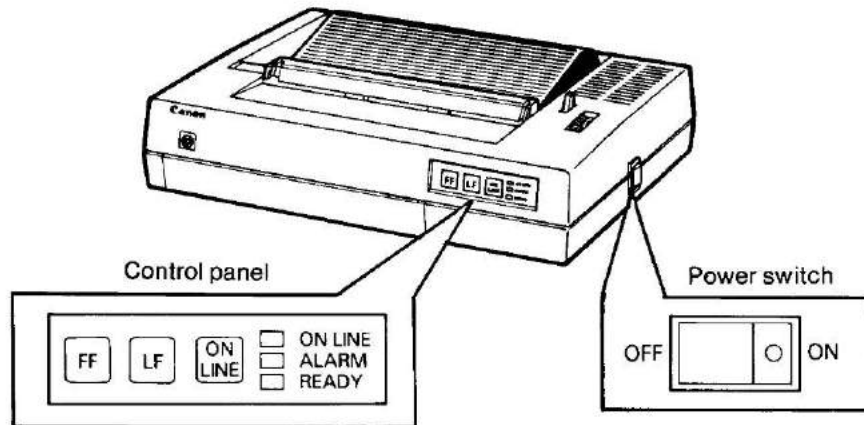

1.2.2 Control Panel

- (1) **FF** (Form Feed) switch: Press this switch to feed the paper to the top of the next page.
- (2) **LF** (Line Feed) switch: Press this switch once to feed the paper by one line. Hold it down to feed the paper continuously.
- (3) **ON LINE** (ON LINE) switch: Switches the printer on-line or off-line. When the printer is off-line, data are not received. When it is on-line, data can be received and printed.

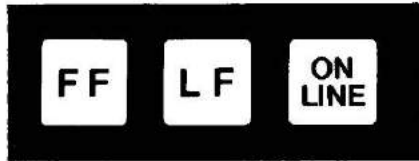

- Notes:**
1. Do not press these switches during printing.
 2. The **FF** and **LF** switches are effective only when the printer is off-line.
 3. The printer is automatically set on-line at power on.

ON LINE
 ALARM
 READY

- (4) **ON LINE** indicator: Lights when the printer is on-line, and goes out when it is off-line.
- (5) **ALARM** indicator:
1. Blinks for about 10 seconds after ink supply pumping has been performed
 2. Lights under the following conditions:
 - No-paper error has occurred.
 - Carriage is locked.
 - Carriage is stopped due to a paper jam.
- (6) **READY** indicator: Lights while the power is on.

2. CONNECTING TO YOUR COMPUTER

This chapter will explain how to connect the printer to your computer. We advise you to use the proper interface cable. (Refer to the section 7).

2.1 Connecting the Ground Cable

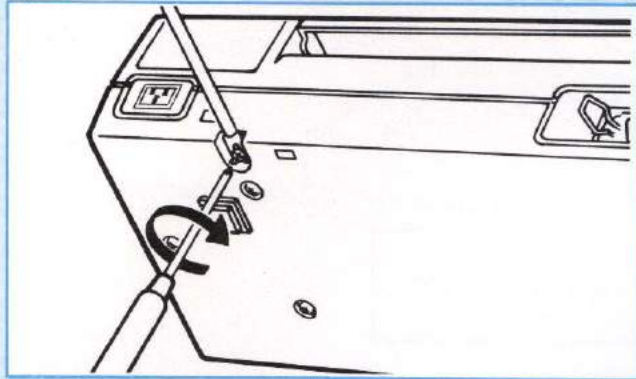

- Tools needed — A Phillips head screwdriver

1. Connect one end of the ground cable to the ground terminal on the back of the printer.

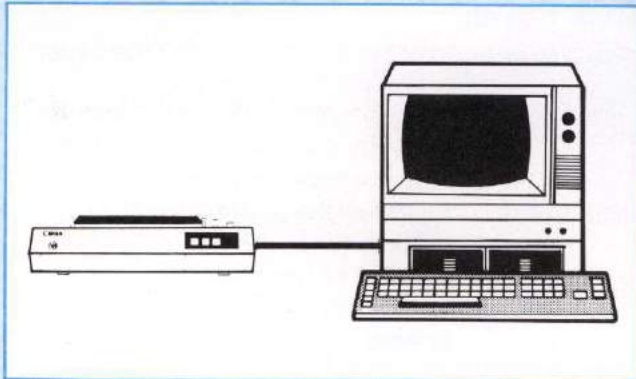

2. Connect the other end to the ground terminal of the computer.

- Notes:**
1. Make sure that the carriage is locked before attaching the ground cable.
 2. Keep the printer as level as possible when attaching the ground cable.

2.2 Connecting the Interface Cable

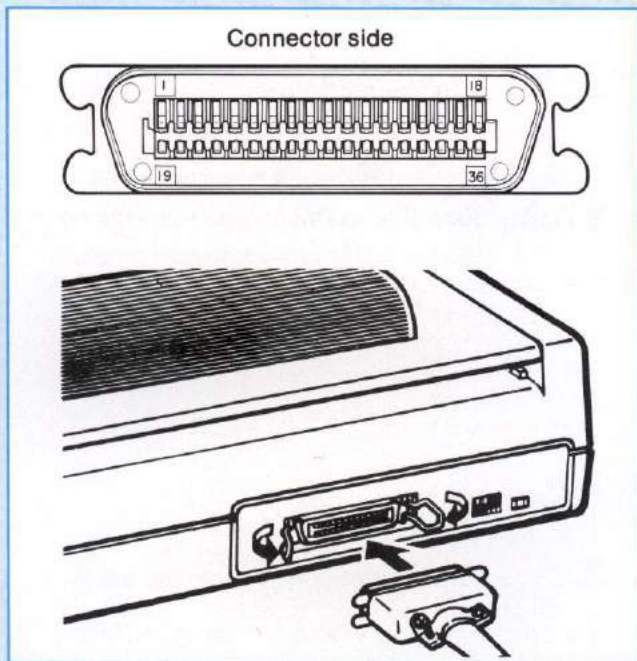

• Tools needed — Nothing

1. Make sure that the power is off.
2. Connect one end of the interface cable to the interface connector and then lock the plug with the clips.

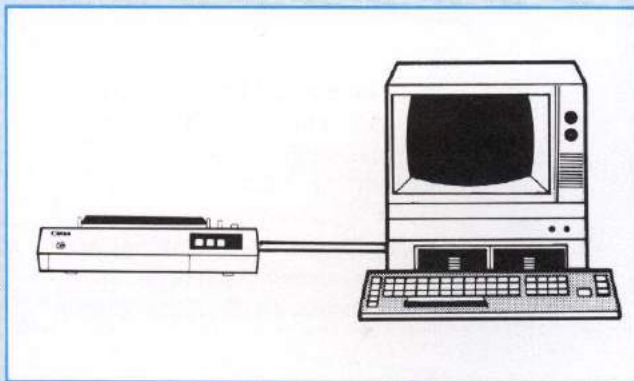

3. Connect the other end to the connector of the computer.

2.3 Connecting the Power Cord

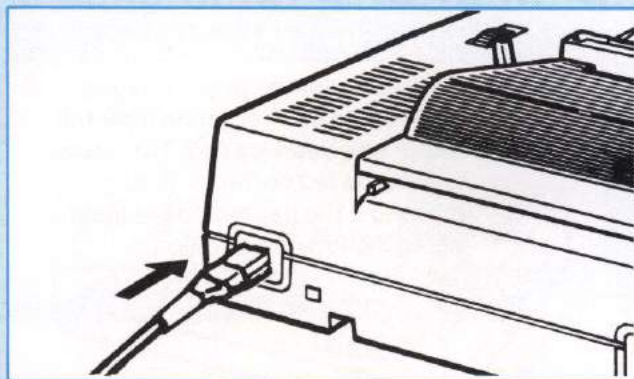

1. Connect the power cord to the printer.
2. Plug the power cord into an AC outlet.

3. LOADING FORMS

Three kinds of forms (roll paper, cut sheets and overhead projection film) can be used with this printer. Always use approved paper or film to ensure optimum print quality.

3.1 Loading Roll Paper

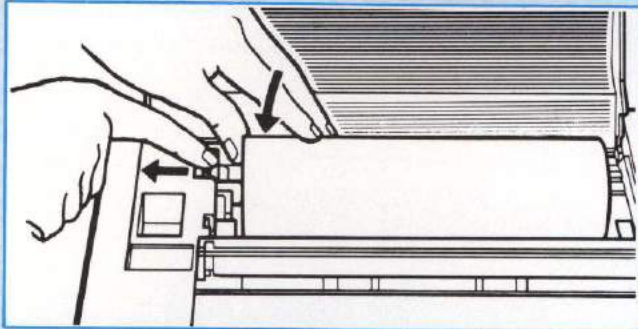

1. Open the roll paper cover and insert the roll by sliding the left roll paper holder as shown.

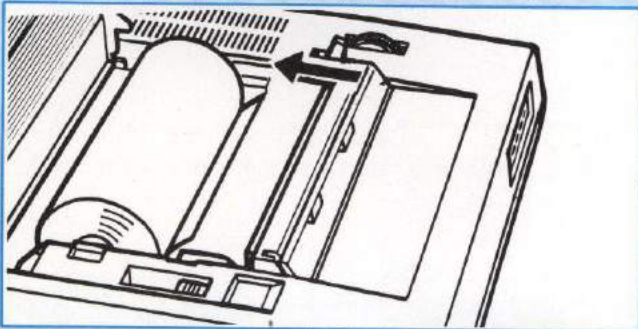

2. Push the paper release lever to the back position.



3. Insert the top of the paper into the paper passage. Turn the paper knob until the paper's edge is level with the paper cutter.

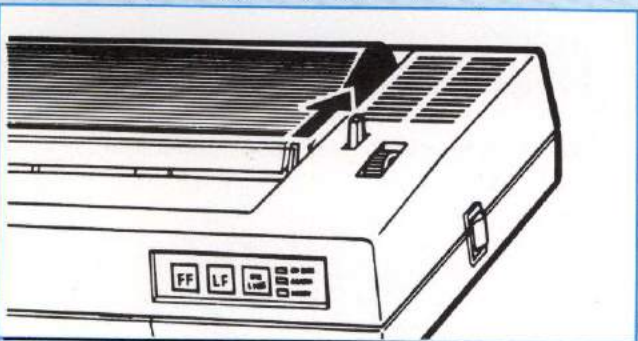

4. Close the paper cover.

Note: Be sure to set the paper release lever to the back position after the paper has been loaded. The paper will not be fed correctly during printing if the paper release lever is set to the forward position.

3.2 Loading Cut Sheets

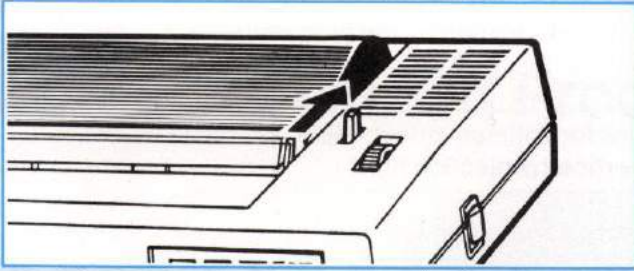

- 1.** Close the paper cover, and push the paper release lever to the back position.

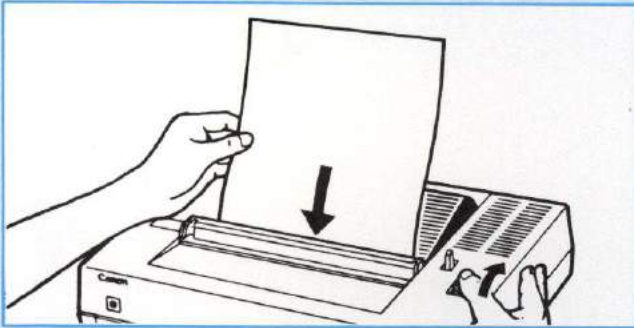

- 2.** Insert the sheet into the paper passage of the paper cover. Turn the paper feed knob until about half the paper is fed.

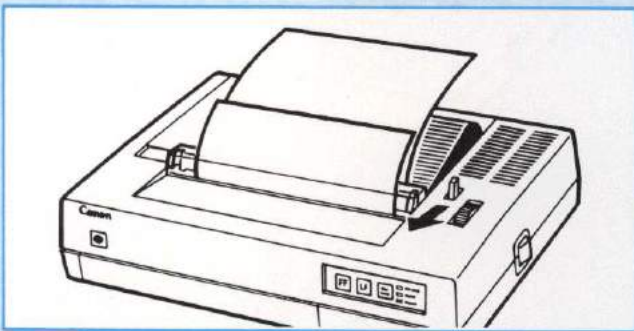

- 3.** Pull the paper release lever to the forward position.

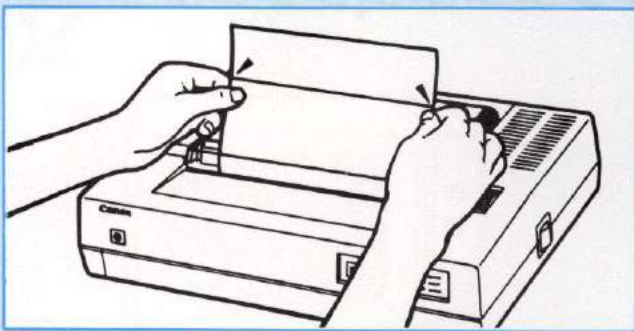

- 4.** Match the edges of the paper to make sure that they are even.



- 5.** Push the paper release lever to the back position. Turn the paper feed knob counterclockwise until the paper is at the desired printing position.

Note: Be sure to push the paper release lever to the back position after the paper has been loaded. The paper will not be fed correctly during printing if the paper release lever is set to the forward position.

3.3 Loading Overhead Projection (OHP) Films

When printing on overhead projection films, install the optional film guide onto the paper cutter beforehand. Refer to the film guide instructions for detailed information on the procedure.

- | |
|--|
| <p>Notes: 1. Use only specified overhead projection films for optimum print quality.
2. Print in the Bold mode when printing on overhead projection films.</p> |
|--|

4. BEFORE PRINTING

This section explains the operations which must be performed before actual printing. Since the three functions of the green lever—unlocking/locking the carriage and ink supply pumping are—very important, please read this section carefully.

4.1 Power On/Off Procedure

The device furthest from the computer should be turned on/off first, and the computer turned on/off last.

Power on: Turn on the printer first.

Power off: Turn off the printer first.

1

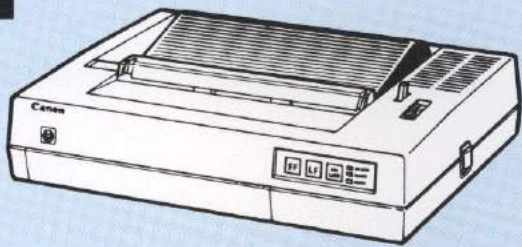

1

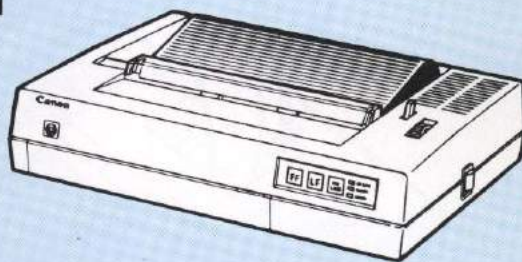

2

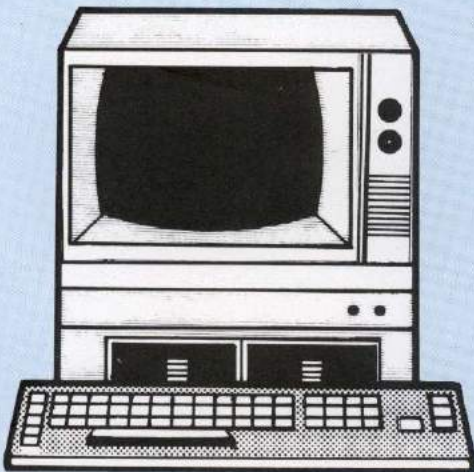

2

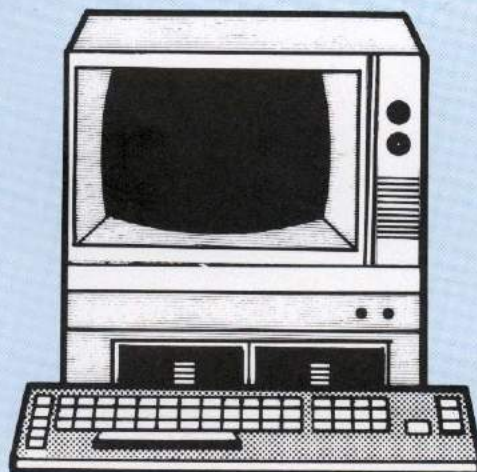

4.2 Unlocking the Carriage

The green lever locks the carriage to protect it from shocks and vibrations when the printer is transported. At the same time, this lever caps the nozzles to prevent the ink from leaking or drying out.



- 1.** The READY and ALARM indicators light when the power is turned on.

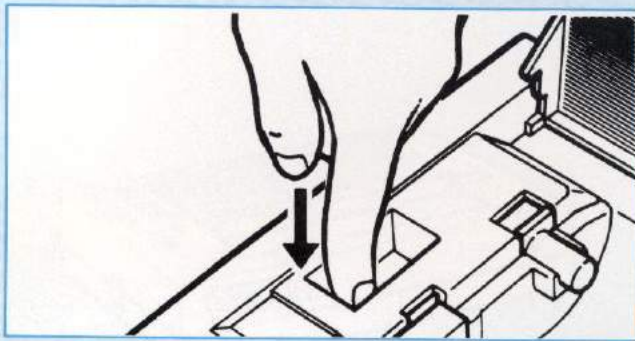

- 2.** Open the roll paper cover. Press the green lever all the way down to the bottom, and hold it there for one second. Release the green lever, and the ALARM indicator will blink for about 10 seconds.

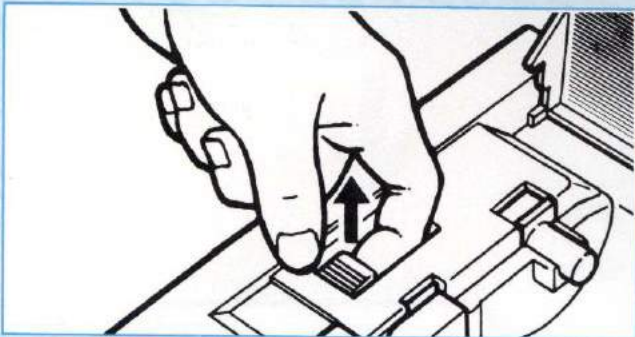

- 3.** When the ALARM indicator stops blinking, lift the green lever up to the top position.

- Unlocking the carriage automatically activates the ink supply mechanism, in addition to unlocking the carriage and uncapping the nozzles.

Note: Do not lift the green lever until the ALARM indicator has stopped blinking.

4.3 Printing Check

After unlocking the carriage as described in Section 4.2, perform the printing check to make sure that the ink-jet printing system is working correctly.

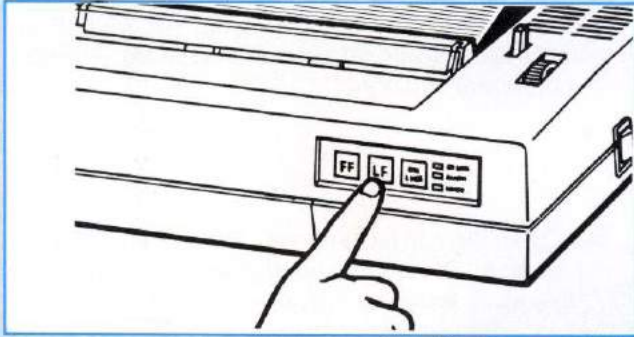

1. Press the **LF** switch, and the printer will start printing the printing check pattern shown below.

Printing Check Pattern



- Notes:**
1. The printing check can be performed only after unlocking the carriage or after performing the ink supply pumping.
 2. If the printing check pattern is not printed correctly, perform the ink supply pumping operation as explained in Section 4.4.

4.4 Ink Supply Pumping Operation

Perform the ink supply pumping operation when the printing check pattern is not printed correctly, there is no printout, or the printout is not clear.

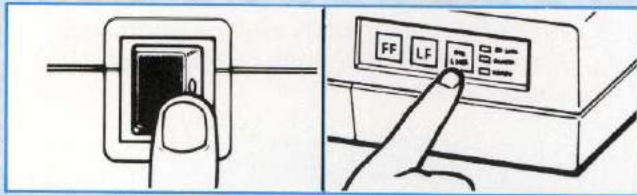

1. Turn on the power. Press the **ON LINE** switch to set the printer off-line, and only the READY indicator will light.

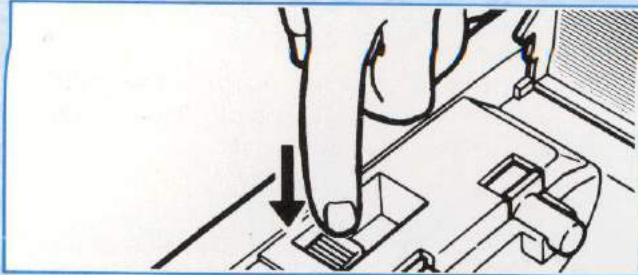

2. Open the roll paper cover. Press the green lever all the way down and hold it for one second. Release the green lever, and the ALARM indicator will blink for about 10 seconds.

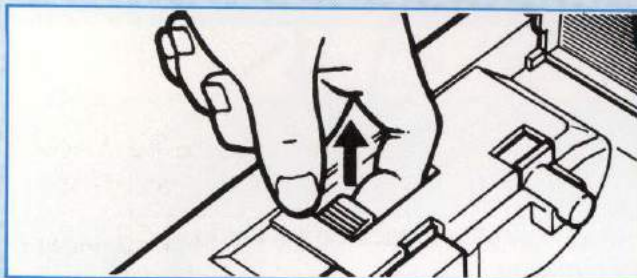

3. When the ALARM indicator stops blinking, lift the green lever up to the top position.

The pumping operation removes ink from the nozzle tips and refills them with new ink. Most printing problems can be solved with this operation.



4. Press the **LF** switch to perform the printing check again.

Notes: 1. If printing problems persist, repeat the above operation 3—5 times.
If a printing problem persists even after the ink supply pumping, check the ink cartridge. Refer to "Section 5 CHANGING INK CARTRIDGES"

2. A shock, vibration, or sudden temperature or air pressure changes will cause air bubbles to form in the nozzles. Such air

bubbles might not be removed with the pumping operation. To rectify this problem, do not operate the printer for at least six hours and then perform the ink supply pumping again.

3. Perform the ink supply pumping only when necessary. Too much pumping will not only waste ink, but it will also lead to problems such as ink overflow, etc.

4.4 Ink Supply Pumping Operation

Perform the ink supply pumping operation when the printing check pattern is not printed correctly, there is no printout, or the printout is not clear.

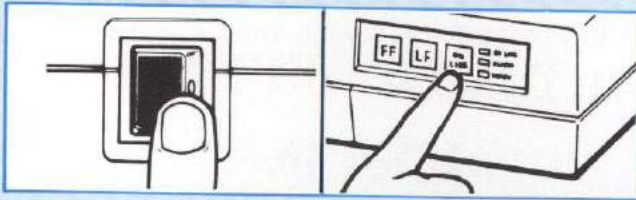

1. Turn on the power. Press the **ON LINE** switch to set the printer off-line, and only the READY indicator will light.

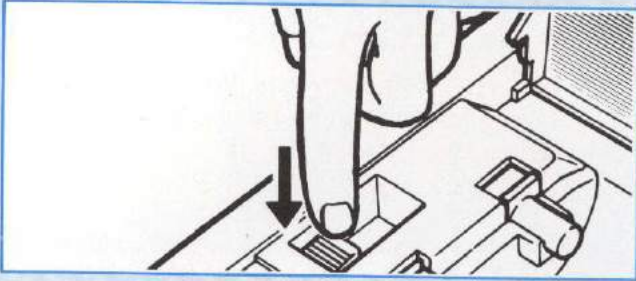

2. Open the roll paper cover. Press the green lever all the way down and hold it for one second. Release the green lever, and the ALARM indicator will blink for about 10 seconds.

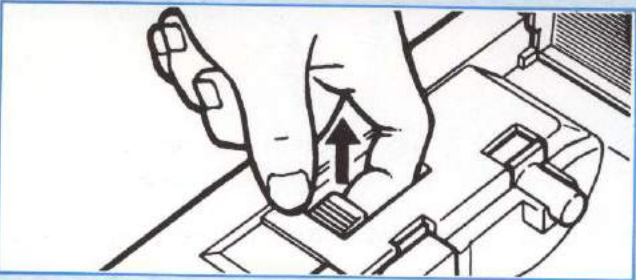

3. When the ALARM indicator stops blinking, lift the green lever up to the top position.

The pumping operation removes ink from the nozzle tips and refills them with new ink. Most printing problems can be solved with this operation.



4. Press the **LF** switch to perform the printing check again.

Notes: 1. If printing problems persist, repeat the above operation 3–5 times.
If a printing problem persists even after the ink supply pumping, check the ink cartridge. Refer to "Section 5 CHANGING INK CARTRIDGES"
2. A shock, vibration, or sudden temperature or air pressure changes will cause air bubbles to form in the nozzles. Such air

bubbles might not be removed with the pumping operation. To rectify this problem, do not operate the printer for at least six hours and then perform the ink supply pumping again.

3. Perform the ink supply pumping only when necessary. Too much pumping will not only waste ink, but it will also lead to problems such as ink overflow, etc.

4.5 Locking the Carriage

Locking the carriage protects the ink-jet printing system from shocks and vibrations that may occur during transportation of the unit. Moreover as described in Section 1.5, locking the carriage executes the ink nozzle capping automatically. Therefore, when transporting or when not using the printer for over a week, lock the carriage as shown below.

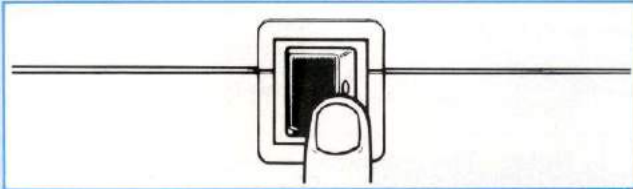

1. Turn on the power.

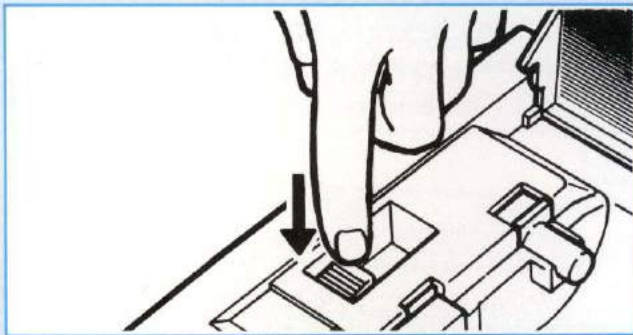

2. Open the roll paper cover. Press the green lever all the way down, hold it down for one second, and then release it.

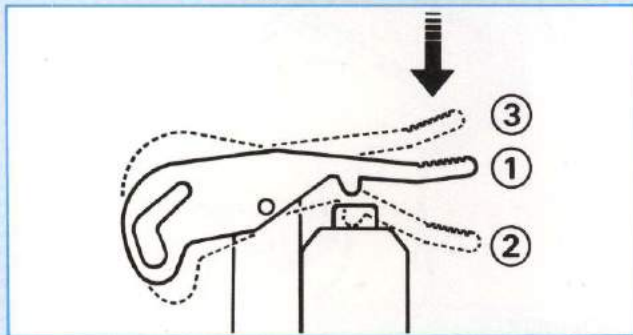

3. The carriage is locked when the green lever stays at the middle position ① after being released.

- ① The carriage is locked and the nozzles are capped.
- ② Ink supply pumping can be performed.
- ③ The carriage is unlocked and the nozzles are uncapped.

Note: The carriage cannot be locked properly if the power is off.

5. CHANGING INK CARTRIDGES

Ink is supplied from two ink cartridges: one black (JI-25B) and one color (JI-20C). A new ink cartridge contains enough ink to print on more than eight rolls of paper per color (3.5 million characters). Use the following criteria to determine when the cartridges should be replaced:

Note: The preloaded ink cartridges have been used at the factory to check the printing quality. Therefore, the amount of printing obtainable with these cartridges will be less than the amount stated at left.

- (1) Printout cannot be obtained for a specific color.
- (2) Printout cannot be obtained even after performing the ink supply pumping.
- (3) The cartridge has already been used to print eight rolls of paper or more.

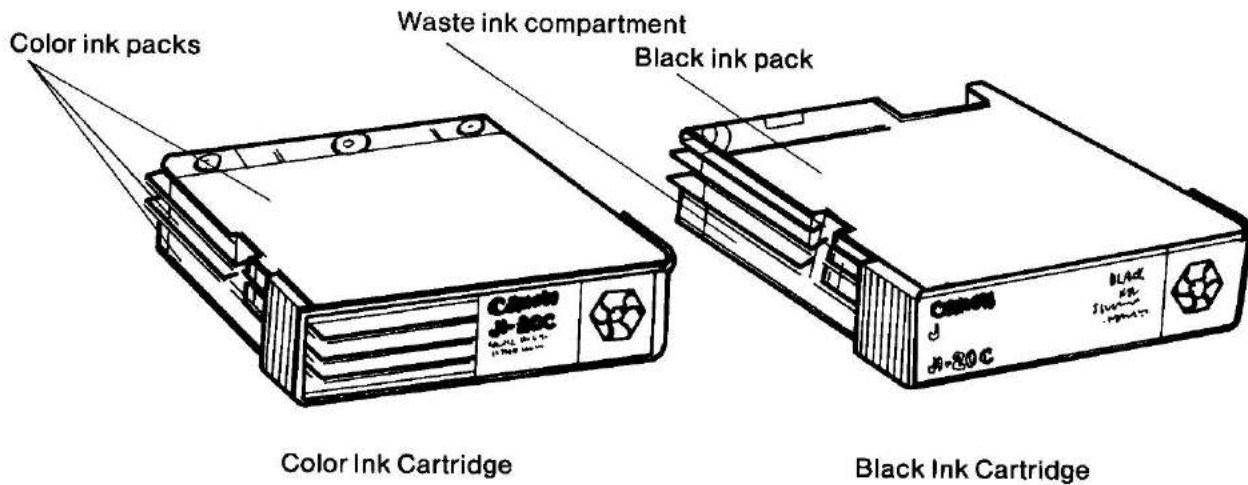

5.1 Checking Ink Levels

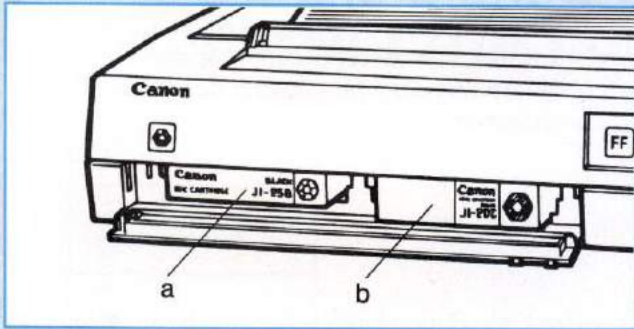

1. Turn off the power. Open the ink cartridge case cover by using a flat object like a coin.
 - a Black ink cartridge (JI-25B)
 - b Color ink cartridge (JI-20C)

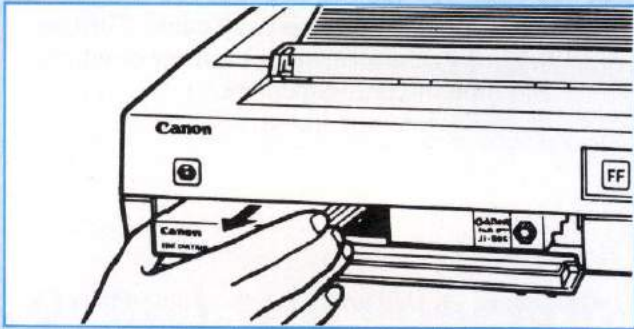

2. Hold the ink cartridge by the sides and pull it straight out of the printer.

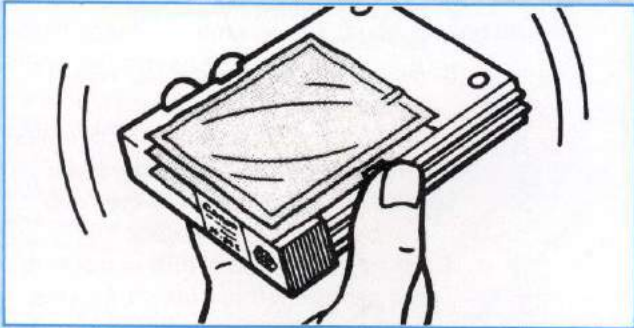

3. Shake the ink cartridge gently from side to side. It is empty if nothing jiggles inside.

5.2 Loading Ink Cartridges

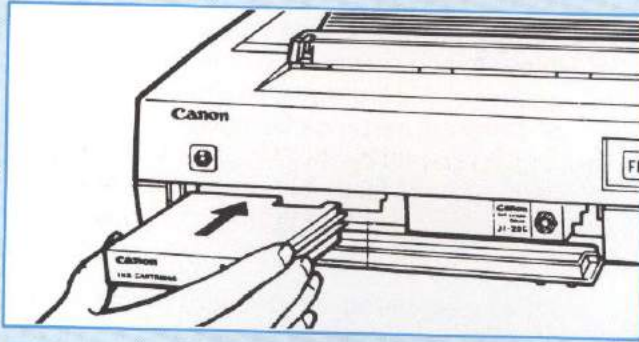

- 1.** Insert the new cartridge firmly into the printer. The safety door will open automatically when the ink cartridge is inserted.

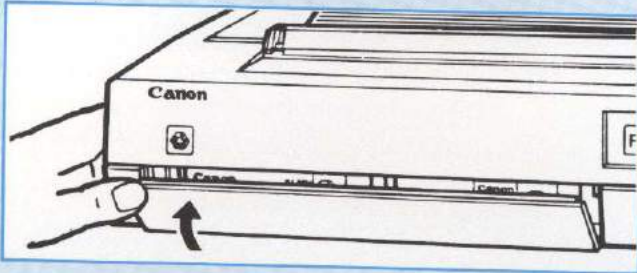

- 2.** Close the ink cartridge case cover. Turn on the power, perform the ink supply pumping, and then the printing check.

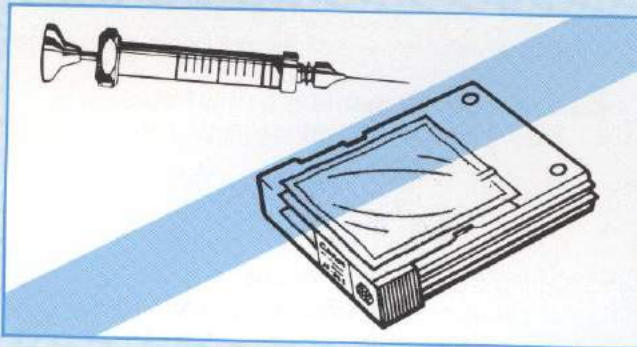

- Cautions:**
- 1. Use only Canon-specified ink cartridges.*
 - 2. Never attempt to refill ink cartridges.*
 - 3. Be careful not to spill the waste ink contained in the black ink cartridge when discarding. Also be careful when discarding a color ink cartridges because they will not be completely empty.*
 - 4. Do not store or attempt to operate the printer without ink cartridges inserted. This can lead to a malfunction or ink leakage.*
 - If ink runs out and there is no replacement ink cartridge on hand, leave the empty cartridge in the printer until you can replace it with a new one.*
 - 5. Do not interchange the black and color ink cartridges, since this might damage the printer.*
 - 6. Do not remove ink cartridges needlessly.*

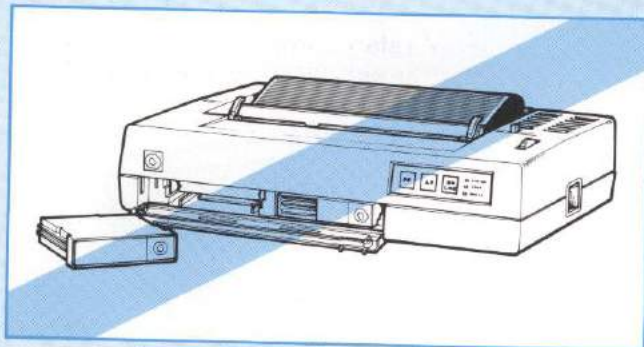

6. FUNCTIONS

The printer has the following built-in functions:

6.1 No-paper Error Function

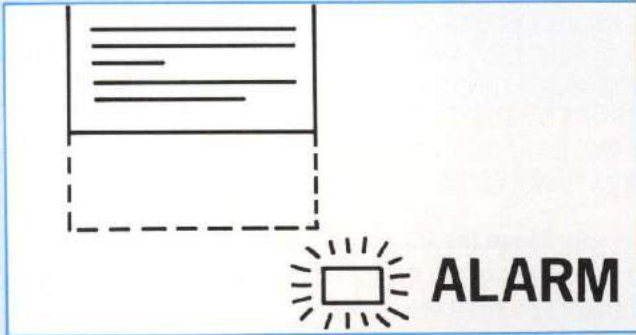

Printing stops, and the ALARM indicator lights when paper is not loaded or has run out. After loading paper, press the **ON LINE** switch to resume printing.

6.2 Self-test Function

The self-test function checks the following items:

- Carriage movement
- Paper feed
- Print quality

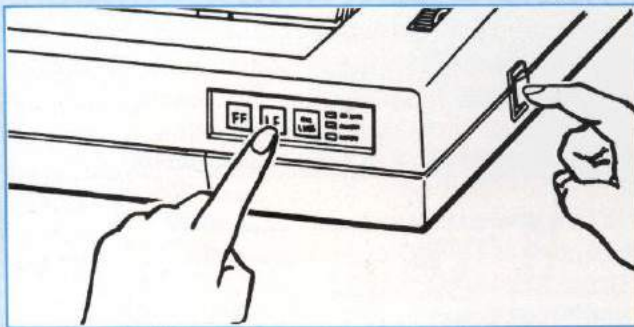

Perform the self-test as follows:

1. Turn on the power while pressing the **LF** switch. You will hear a beep when the power is turned on.
2. The printer will start printing.
3. To terminate the self-test, turn the power off.

6.3 Bold Print Function

Set the bold switch on the printer's rear panel to BOLD to print on overhead projection films or to print bold characters on ordinary paper. For standard printing, set it to NORM.

- Use bold print when printing on Overhead projection films for clear printout.

Printing comparison

Normal Characters

!! P R I N T E R !!

Bold Characters

!! P R I N T E R !!

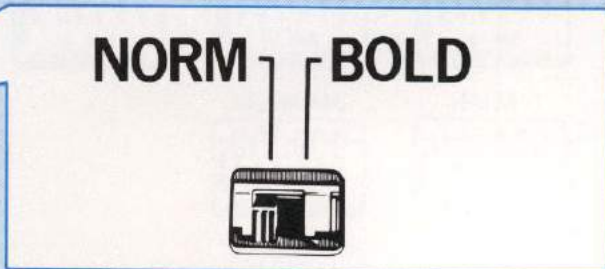
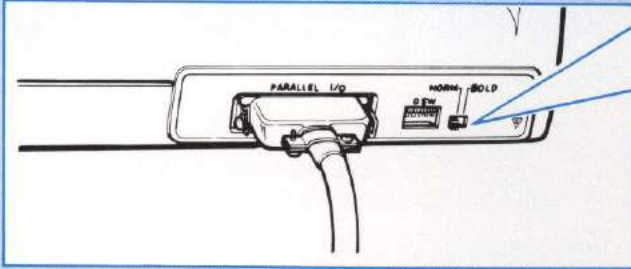

6.4 The DIP Switch

Many functions can be used just by resetting the DIP switch selectors on the printer's rear panel.

1. DIP switch selector positions

The six selectors of the DIP switch are set as shown for various functions. All selectors are set to ON at the factory prior to shipment.

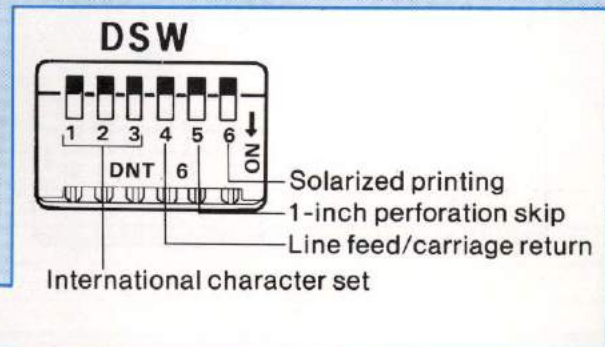
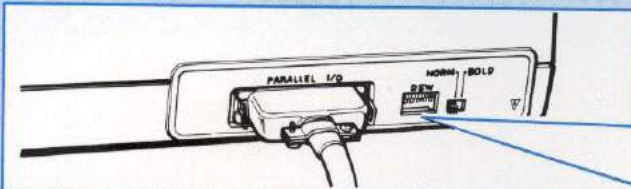

Cautions regarding the DIP switch

- Turn off the power when switching the selector positions.
- Use a pointed object such as a ball-point pen (pointed but not sharp) to gently set the selectors. Do not use force which might damage the selectors.

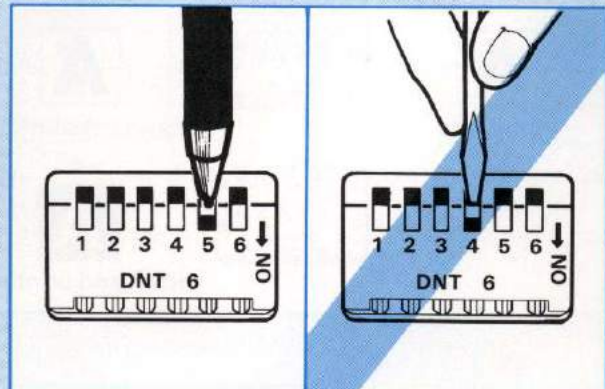

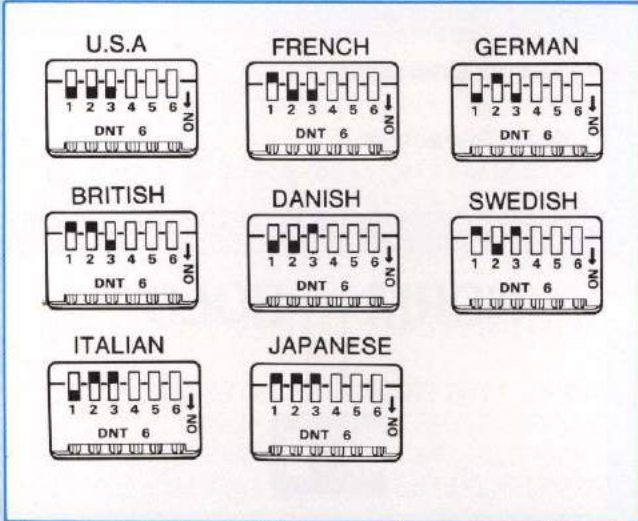

2. International character set

Selectors 1, 2 and 3 are used to select international character sets as shown at left.

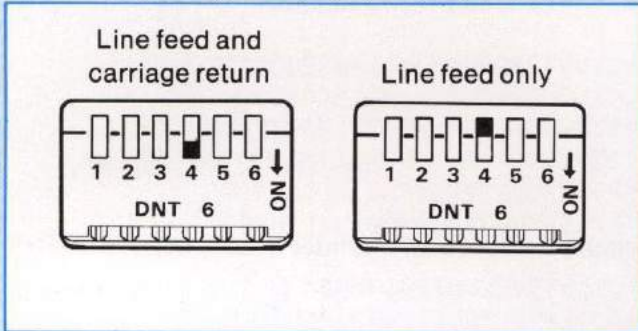

3. Line feed/carriage return

Selector 4 is used to set the line feed/carriage return function. Depending on the position of this selector, the printer will feed a line and return the carriage to the home position (ON), or just feed a line after printing the data in the print buffer.

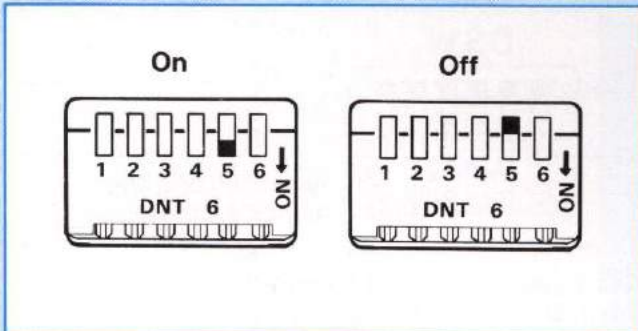

4. 1-inch perforation skip

Selector 5 is used to turn the 1-inch perforation skip function on and off.

Note: Turn this function off when using roll paper.

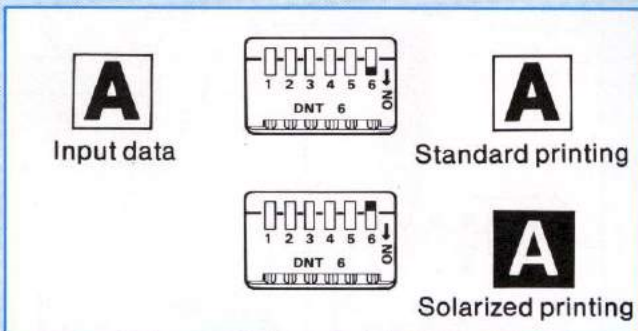

5. Standard/solarized printing

Selector 6 is used to select standard printing or solarized printing (negatives and positives printed in reverse).

7. INTERFACE SPECIFICATIONS

7.1 Data transmission method

8-bit parallel interface (Centronics type)

7.2 Signal level (TTL level)

Low: +0.0V~+0.4V

High: +2.4V~+5.0V

7.3 Input circuits

A Input signal

B SN74LS14 or equivalent

C SN74LS37 or equivalent

7.4 Connection cable

Material: Over AWG 28

Length: Up to 2.0 m (twisted pair shielded cable)

7.5 Connectors

Printer side: Amphenol 57-30360 or equivalent

Cable side: Amphenol or equivalent

7.6 Connection table

Note: –RET signal is always connected to GND.

Pin No	Signal	Direction	Pin No.	Signal	Direction
1	<u>DSTB</u>	In	19	<u>DSTB-RET</u>	
2	DATA 1 (LSB)	In	20	DATA 1-RET	
3	DATA 2	In	21	DATA 2-RET	
4	DATA 3	In	22	DATA 3-RET	
5	DATA 4	In	23	DATA 4-RET	
6	DATA 5	In	24	DATA 5-RET	
7	DATA 6	In	25	DATA 6-RET	
8	DATA 7	In	26	DATA 7-RET	
9	DATA 8 (MSB)	In	27	DATA 8-RET	
10	<u>ACKNLG</u>	Out	28	<u>ACKNLG-RET</u>	
11	BUSY	Out	29	BUSY-RET	
12	PE	Out	30	GND (0V)	
13	SLCT	Out	31	<u>INIT</u>	In
14	NC		32	<u>ERROR</u>	Out
15	NC		33	GND (0V)	
16	GND (0V)		34	NC	In
17	CHS/GND		35	+5V	
18	NC		36	NC	

7.7 Explanation of input signals

DATA 1 ~8

- Used for 1 to 8 bits of parallel and image data.
- Loaded by the $\overline{\text{DSTB}}$ signal.
- This signal should not be changed for $1 \mu\text{s}$ after $\text{DSTB}=\text{High}$.

$\overline{\text{DSTB}}$

- Used for loading DATA 1 ~8.
- Becomes effective upon $\text{BUSY}=\text{Low}$. However, also becomes effective upon $\text{BUSY}=\text{High}$ and $\text{SLCT}=\text{Low}$ when using the DC1 code.
- When $\text{BUSY}=\text{High}$ and $\text{SLCT}=\text{Low}$, all codes except the DC1 code are ignored.
- Do not send the next $\overline{\text{DSTB}}$ signal until $\text{BUSY}=\text{Low}$ has been sent.
- The printer starts operating when $\overline{\text{DSTB}}=\text{High}$.

$\overline{\text{INIT}}$

- Used for initializing the printer.
- If this signal is received during operation, the printer stops operating immediately.
- Initialization is executed when this signal goes from Low to High.
- This signal functions when the printer is turned on.
- This signal is received when the alarm lights.
- The following operations are carried out when the printer is initialized:
 1. The print head is returned to the home position (extreme left).
 2. The print buffer is cleared.
 3. Printing is set to the Standard mode.
 4. The line feed pitch is set to 1/6 inch.

7.8 Explanation of output signals

$\overline{\text{ACKNLG}}$

- A response signal to $\overline{\text{DSTB}}$.
- This is a minus pulse signal (approximately $12 \mu\text{s}$) which is sent after the BUSY signal has changed from High to Low, or after data entry.
- Do not send the next $\overline{\text{DSTB}}$ signal until this signal has been sent.
- This signal can be sent without sending the $\overline{\text{DSTB}}$ signal under the following conditions:
 1. When the printer is turned on, or when the SLCT signal is changed to High for the $\overline{\text{INIT}}$ signal.
 2. After pressing the  switch when the SLCT signal is changed from Low to High after the DC1 code is entered.
- This signal will not be sent even if the BUSY signal is High after the DC3 code is entered.

BUSY

- Indicates that the printer is BUSY when this signal is High. Codes other than the DC1 code will be ignored.
- This signal switches to High under the following conditions:
 1. During data input
 2. During printing
 3. During the execution of control codes
 4. When the alarm lights
 5. During the Deselect mode (nothing can be received or transmitted)

PE

- In an out-of-paper condition when $\overline{\text{SLCT}} = \text{Low}$, this signal becomes High, the ALARM indicator lights, and the $\overline{\text{LF}}$ switch becomes inoperative.
- In an out-of-paper condition when $\overline{\text{SLCT}} = \text{High}$ during printing or the execution of a printing function, the ALARM indicator lights after printing or the execution of the printing function. This signal becomes High, the $\overline{\text{SLCT}}$ signal becomes Low, and the $\overline{\text{LF}}$ switch becomes inoperative.
- When paper is loaded, this signal changes from High to Low, the ALARM indicator goes off, and the $\overline{\text{LF}}$ switch becomes operative. However, the $\overline{\text{SLCT}}$ signal remains Low. Therefore, press the $\overline{\text{ON LINE}}$ switch or input the DC1 code to set the $\overline{\text{SLCT}}$ signal to High.

SLCT

- Indicates the Deselect mode when this signal is Low, and $\overline{\text{BUSY}} = \text{High}$ and $\overline{\text{ERROR}} = \text{Low}$.
- The printer is set to the Deselect mode (communication not possible) when one of the following occurs:
(The $\overline{\text{ACKNLG}}$ signal is not sent.)
 1. The $\overline{\text{ON LINE}}$ switch is pressed in the Select mode (communication possible), or the DC3 code is received.
 2. No paper, a) when the printer is turned on; or b) when initializing with the $\overline{\text{INIT}}$ signal.
 3. No paper after printing.
- Indicates the Select mode when this signal is High. (The ON LINE indicator is lit.)
- The printer is set to the Select mode when one of the following occurs:
(The $\overline{\text{ACKLNG}}$ signal is sent.)
 1. New paper is loaded in the no-alarm state after the printer has been turned on or after the printer has been initialized with the $\overline{\text{INIT}}$ signal.
 2. The $\overline{\text{ON LINE}}$ switch is pressed in the Deselect mode or the printer is initialized with the DC1 code. In both cases, the printer must be in the no-alarm state.

ERROR

- This signal becomes Low under the following conditions:
 1. Alarm status (The ALARM indicator lights.)
 2. $\overline{\text{SLCT}} = \text{Low}$
 3. Carriage motor malfunction
 4. Operation of the carriage lock lever (including the ink supply pumping)
 5. The printer is off-line.

7.9 Interface Timing Chart

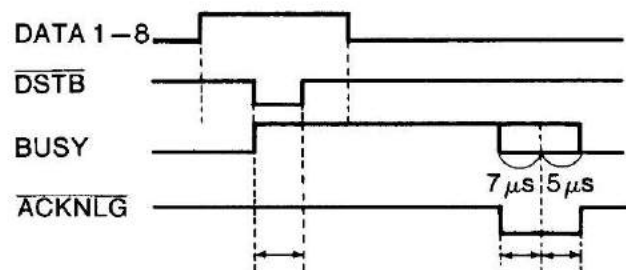

- The $\overline{\text{BUSY}}$ signal can be selected during the falling edge (7 μs duration) or the rising edge (5 μs duration) after an $\overline{\text{ACKNLG}}$ signal.

SOFTWARE

By sending control codes from the computer, the Canon Ink-Jet Printer can be made to execute many functions. This chapter explains how to use each control code, and also provides program samples that you can try.

1. BASIC CONTROL CODES

There are 14 basic control codes which can be used to control printing movements and paper feed, and to set the page format, perforation skip and tabs.

1.1 Printing Movements

CR

Carriage Return – Printing and Carriage Return

Code: <0D>_H or <13>₁₀
BASIC Syntax: CHR\$ (&HD); or CHR\$ (13);

Function: When this code is entered, all data stored in the print buffer are printed.

- If no data precede the CR code (only the CR code is in the print buffer), the carriage will not move.
- Input of the CR code with line feed will cancel the Enlarged mode set with the SO code.

Example: After printing "Print" several times, the carriage is returned to the home position, and "CR" is also printed several times on the same line.

[Program]

```
10 REM CARRIAGE RETURN
20 LPRINT "PRINT PRINT PRINT PRINT ";CHR$(13);
30 LPRINT " CR CR CR CR"
40 END
```

[Printout]

```
PRINT CR PRINT CR PRINT CR PRINT CR
```

CAN

Cancelling Print Buffer Data

Code: <18>_H or <24>₁₀
BASIC Syntax: CHR\$ (&H18); or CHR\$ (24);

Function: When this code is entered, the last line of print data in the print buffer that precedes this code is cancelled.

- Only the print data are cancelled.

Example: Cancelling print buffer data.

[Program]

```
10 REM CANCEL
20 LPRINT "AAAAAAAAAAAAAAAAAAAA";
30 LPRINT CHR$(24);
40 LPRINT "BBBBBBBBBBBBBBBBBBB"
50 END
```

[Printout]

```
BBBBBBBBBBBBBBBBBBB
```

1.2 Line Feed

LF

Line feed

Code: $\langle 0A \rangle_H$ or $\langle 10 \rangle_{10}$
BASIC Syntax: CHR\$(&HA); or CHR\$(10);

Function: When this code is entered, all the data in the print buffer are printed and then a line feed is executed.

- If no data precede the LF code (only the LF code is present in the print buffer), only a line feed is executed.
- Input of the LF code will cancel the Enlarged mode set with the SO code.
- The line feed rate may be set with the ESC *0" or ESC *2" codes.

Note: The color codes set prior to the execution of the LF code remain effective.

Example: After printing "Print", the paper is fed one line, and then "LF" is printed.

[Program]

```
10 REM LINE FEED
20 LPRINT "PRINT";CHR$(10);"LF"
30 END
```

[Printout]

```
PRINT
  LF
```

ESC "0"

1/8-inch Line Spacing

Code: <1B>_H <30>_H or <27>₁₀ <48>₁₀
BASIC Syntax: CHR\$(&H1B); "0"; or CHR\$(27); "0";

Function: When this code is entered, the amount of line spacing is set to 1/8 inch.

Example: Printing 10 lines with 1/8-inch line spacing.

[Program]

```
10 REM LINE SPACE
20 LPRINT CHR$(27);"0"
30 FOR I=1 TO 10
40   LPRINT "----- 1/8 (inch Per line) -----"
50 NEXT I
60 END
```

[Printout]

```
----- 1/8 (inch Per line) -----
----- 1/8 (inch Per line) -----
----- 1/8 (inch Per line) -----
----- 1/8 (inch Per line) -----
----- 1/8 (inch Per line) -----
----- 1/8 (inch Per line) -----
----- 1/8 (inch Per line) -----
----- 1/8 (inch Per line) -----
----- 1/8 (inch Per line) -----
----- 1/8 (inch Per line) -----
```

ESC "2"**1/6-inch Line Spacing**

Code: <1B>_H <32>_H or <27>₁₀ <50>₁₀
BASIC Syntax: CHR\$(&H1B); "2"; or CHR\$(27); "2";

Function: When this code is entered, the amount of line spacing is set to 1/6 inch.

Example: Printing 10 lines with 1/6-inch line spacing.

[Program]

```
10 REM LINE SPACE
20 LPRINT CHR$(27);"2"
30 FOR I=1 TO 10
40   LPRINT "----- 1/6 (inch Per line) -----"
50 NEXT I
60 END
```

[Printout]

```
----- 1/6 (inch Per line) -----
----- 1/6 (inch Per line) -----
----- 1/6 (inch Per line) -----
----- 1/6 (inch Per line) -----
----- 1/6 (inch Per line) -----
----- 1/6 (inch Per line) -----
----- 1/6 (inch Per line) -----
----- 1/6 (inch Per line) -----
----- 1/6 (inch Per line) -----
----- 1/6 (inch Per line) -----
```

1.3 Page Format

ESC "C" +0+n

Page Length by Inches

Code: <1B>_H <43>_H <00>_H <n> or <27>₁₀ <67>₁₀
 <0>₁₀ <n>

BASIC Syntax: CHR\$(&H1B); "C"; CHR\$(0); CHR\$(n); or
CHR\$(27); "C"; CHR\$(0); CHR\$(n);
(1 ≤ n ≤ 22)

Function: When this code is entered, the page length is set
 to n inches.

- Form feed, perforation skip, etc. are executed in accordance with the page length set with this code.
- The page length is set to 11 inches at power on.

Example: Setting the page length to 3 inches, and the amount of line spacing to 1/8 inch for the first page and to 1/6 inch for the second page.

[Program]

```
100 REM INCHES PER PAGE
110 LPRINT CHR$(27);"C";CHR$(0);CHR$(3)
120 LPRINT CHR$(27);"0"
130 FOR I=1 TO 5
140   LPRINT "----- Page length (3 inches/Page) 1/8 inch/line -----"
150 NEXT I
160 LPRINT CHR$(8HC)
170 LPRINT CHR$(27);"2";
180 FOR I=1 TO 5
190   LPRINT "----- Page length (3 inches/Page) 1/6 inch/line -----"
200 NEXT I
210 END
```

ESC "C" +0+n

Page Length by Inches

[Printout]

```

----- Page length (3 inches/Page) 1/8 inch/line -----
----- Page length (3 inches/Page) 1/8 inch/line -----
----- Page length (3 inches/Page) 1/8 inch/line -----
----- Page length (3 inches/Page) 1/8 inch/line -----
----- Page length (3 inches/Page) 1/8 inch/line -----

```

```

----- Page length (3 inches/Page) 1/6 inch/line -----
----- Page length (3 inches/Page) 1/6 inch/line -----
----- Page length (3 inches/Page) 1/6 inch/line -----
----- Page length (3 inches/Page) 1/6 inch/line -----
----- Page length (3 inches/Page) 1/6 inch/line -----

```

ESC "C" +n

Page Length by Lines

Code: <1B>_H <43>_H <n> or <27>₁₀
 <67>₁₀ <n>

BASIC Syntax: CHR\$(&H1B); "C"; CHR\$(n); or CHR\$(27); "C";
 CHR\$(n);
 (1 ≤ n ≤ 127)

Function: **When this code is entered, the page length is set to n times the amount of line spacing.**

- Once the page length is set with this code, the page length will not change even if the amount of line spacing is changed.
- Form feed, perforation skip, etc. are executed in accordance with the page length set with this code.
- The page length is set to 66 lines at power on.

Example: Setting the page length to 10 lines, and the amount of line spacing to 1/8 inch for the first page, and to 1/6 inch for the second page.

[Program]

```
100 REM LINE NUMBER PER PAGE
110 LPRINT CHR$(27);"C";CHR$(10)
120 LPRINT CHR$(27);"0"
130 FOR I=1 TO 5
140   LPRINT "----- Page length, (10 (lines/Page) 1/8 inch/line -----"
150 NEXT I
160 LPRINT CHR$(&HC);
170 LPRINT CHR$(27);"2"
180 FOR I=1 TO 5
190   LPRINT "----- Page length (10 (lines/Page) 1/6 inch/line -----"
200 NEXT I
210 END
```

ESC "C" +n**Page Length by Lines***[Printout]*

```

----- Page length (10 lines/Page) 1/8 inch/line -----
----- Page length (10 lines/Page) 1/8 inch/line -----
----- Page length (10 lines/Page) 1/8 inch/line -----
----- Page length (10 lines/Page) 1/8 inch/line -----
----- Page length (10 lines/Page) 1/8 inch/line -----

```

```

----- Page length (10 lines/Page) 1/6 inch/line -----
----- Page length (10 lines/Page) 1/6 inch/line -----
----- Page length (10 lines/Page) 1/6 inch/line -----
----- Page length (10 lines/Page) 1/6 inch/line -----
----- Page length (10 lines/Page) 1/6 inch/line -----

```

FF

Form Feed

Code: <0C>_H or <12>₁₀
BASIC Syntax: CHR\$(&HC); or CHR\$(12);

Function: When this code is entered, all the data in the printer buffer are printed, and then the paper is fed to the top of the next page in accordance with the preset page length.

- The top-of-page position is set at power on, or when the ESC "@ " code is entered.
- The page length is set to 11 inches at power on.
- The FF code cancels the Enlarged mode with automatic self-cancellation set with the SO code.

Example: The page length is set to 7 lines, and after printing 2 lines, the paper is fed to the top of the next page.

[Program]

```
100 REM FORM FEED
110 LPRINT CHR$(27);"C";CHR$(7)
120 LPRINT "   Line number 1"
130 LPRINT "   Line number 2"
140 LPRINT CHR$(12);
150 LPRINT "   Line number 1"
160 END
```

[Printout]

```
Line number 1
Line number 2
```

```
Line number 1
```

1.4 Perforation Skip

ESC "N" +n

Perforation Skip (n Lines)

Code: $\langle 1B \rangle_H \langle 4E \rangle_H \langle n \rangle$ or $\langle 27 \rangle_{10} \langle 78 \rangle_{10} \langle n \rangle$
BASIC Syntax: CHR\$(&H1B); "N"; CHR\$(n); or CHR\$(27);
"N"; CHR\$(n);
($1 \leq n \leq 127$)

Function: When this code is entered, the paper will be fed by n lines at the bottom of the page.

- When the No.5 selector of the DIP switch is OFF, a one-inch perforation skip is executed instead of the specified amount.
- The perforation skip function is cancelled when the page length is changed with the ESC ^C + n or ESC ^C + 0 + n codes.

Example 1: Printing with the page length set to 5 lines and the amount of perforation skip set to 2 lines, (n=2).

[Program]

```
10 REM SETTING PERFORATION SKIP
20 LPRINT CHR$(27);"C";CHR$(5);
30 LPRINT CHR$(27);"N";CHR$(2);
40 FOR I=1 TO 20
50   LPRINT "   This line is ";I;" -----"
60 NEXT I
70 END
```

ESC "N" +n

Perforation Skip (n Lines)

[Printout]

This line is 1 -----
This line is 2 -----
This line is 3 -----

This line is 4 -----
This line is 5 -----
This line is 6 -----

This line is 7 -----
This line is 8 -----
This line is 9 -----

This line is 10 -----
This line is 11 -----
This line is 12 -----

This line is 13 -----
This line is 14 -----
This line is 15 -----

This line is 16 -----
This line is 17 -----
This line is 18 -----

This line is 19 -----
This line is 20 -----

ESC "N" +n

Perforation Skip (n Lines)

Example 2: Printing with the page length set to 1 inch and the amount of perforation skip set to 1 line. (n=1).

[Program]

```
10 REM SETTING PERFORATION SKIP
20 LPRINT CHR$(27);"C";CHR$(0);CHR$(1);
30 LPRINT CHR$(27);"N";CHR$(1);
40 FOR I=1 TO 20
50   LPRINT "   This line is ";I;" -----"
60 NEXT I
70 END
```

[Printout]

```
This line is 1 -----
This line is 2 -----
This line is 3 -----
This line is 4 -----
This line is 5 -----

This line is 6 -----
This line is 7 -----
This line is 8 -----
This line is 9 -----
This line is 10 -----

This line is 11 -----
This line is 12 -----
This line is 13 -----
This line is 14 -----
This line is 15 -----

This line is 16 -----
This line is 17 -----
This line is 18 -----
This line is 19 -----
This line is 20 -----
```

ESC "O"**Cancelling Perforation Skip**

Code: <1B>_H <4F>_H or <27>₁₀ <79>₁₀
BASIC Syntax: CHR\$(&H1B); "O"; or CHR\$(27); "O";

Function: This code cancels the perforation skip function.

Example: Printing 6 lines with the page length set to 3 lines and the amount of perforation skip to 2 lines, and then printing 4 lines after cancelling the perforation skip function.

[Program]

```
10 REM CANCELLING PERFORATION SKIP
20 LPRINT CHR$(27);"C";CHR$(5);
30 LPRINT CHR$(27);"N";CHR$(2);
40 FOR I=1 TO 10
50   LPRINT "   This line is ";I;" -----"
60 IF I=6 THEN LPRINT CHR$(27);"O"
70 NEXT I
80 END
```

[Printout]

```
This line is 1 -----
This line is 2 -----
This line is 3 -----
```

```
This line is 4 -----
This line is 5 -----
This line is 6 -----
```

```
This line is 7 -----
This line is 8 -----
This line is 9 -----
This line is 10 -----
```

1.5 Tabs

ESC "D" +n₁+n₂+...+n_k+0

Setting Horizontal Tab Positions

Code: <1B>_H <44>_H <n₁> <n₂> ... <n_k> <00>_H or
<27>₁₀ <68>₁₀ <n₁> <n₂> ... <n_k> <0>₁₀

BASIC Syntax: CHR\$(&H1B); "D"; CHR\$(n₁); CHR\$(n₂); ... ;
CHR\$(n_k); CHR\$(0); or CHR\$(27); "D"; CHR\$(
(n₁); CHR\$(n₂); ... ; CHR\$(n_k); CHR\$(0);
(1 ≤ n ≤ 80, 1 ≤ k ≤ 32)

Function: This code is used to set the horizontal tab positions.

- A horizontal position = the amount of the current character width × the number of character positions (n_k)
- The horizontal tab positions should be set in the order of increasing values. If they are not, only the positions in the correct order will be set, and the rest will be ignored. Input the NUL code (<00>_H, <0>₁₀) to terminate the setting operation.
- When the HT code is entered, the carriage skips to the next horizontal tab position, and printing is resumed from the position after the horizontal tab position.

Example 1: Setting the horizontal tabs at the 10th, 20th, and 30th positions.

[Program]

```
10 REM HORIZONTAL TABULATION SET
20 LPRINT CHR$(27);"D";CHR$(10);CHR$(20);CHR$(30);CHR$(0)
```

Example 2: Making a mistake in the order of tab positions.

[Program]

```
10 REM HORIZONTAL TABULATION
20 LPRINT "----*----1----*----2----*----3----*----4----*"
30 LPRINT CHR$(27);"D";CHR$(4);CHR$(12);CHR$(8);CHR$(30);CHR$(40);CHR$(0);
40 FOR I=1 TO 5
50   LPRINT CHR$(9);"H-TAB";
60 NEXT I
70 END
```

[Printout]

```
----*----1----*----2----*----3----*----4----*
      H-TAB  H-TABH-TABH-TABH-TAB
```

HT

Executing Horizontal Tabs

Code: $\langle 09 \rangle_{\text{H}}$ or $\langle 9 \rangle_{10}$
BASIC Syntax: CHR\$(&H9); or CHR\$(9);

Function: The HT code executes the set horizontal tabs.

- The HT code is ignored when horizontal tab positions have not been set.
- Horizontal tabs are set at every 8th position at power on.
- Horizontal tabs are stored as absolute positions; therefore, they will not change even if the print mode is changed.

Example 1: Printing with the horizontal tabs set at the 4th, 12th, 18th, and 26th positions.

[Program]

```
10 REM HORIZONTAL TABULATION
20 LPRINT "----*----1----*----2----*----3----*----4"
30 LPRINT CHR$(27);"D";CHR$(4);CHR$(12);CHR$(18);CHR$(26);CHR$(0);
40 FOR I=1 TO 4
50   LPRINT CHR$(9);"H-TAB";
60 NEXT I
70 END
```

[Printout]

```
----*----1----*----2----*----3----*----4
   H-TAB  H-TAB H-TAB  H-TAB
```

HT

Executing Horizontal Tabs

Example 2: Printing enlarged characters with the horizontal tabs set at the 4th, 22nd, 35th and 48th positions.

[Program]

```

100 REM HORIZONTAL TABULATION
110 LPRINT "----*----1----*----2----*----3----*----4----*----5----*----6"
120 LPRINT CHR$(27);"D";CHR$(4);CHR$(22);CHR$(35);CHR$(48);CHR$(0);
130 LPRINT CHR$(27);"W";CHR$(1);
140 FOR I=1 TO 4
150   LPRINT CHR$(9);"H-TAB";
160 NEXT I
170 LPRINT CHR$(27);"W";CHR$(0);
180 END

```

[Printout]

```

----*----1----*----2----*----3----*----4----*----5----*----6
H-TAB      H-TAB      H-TAB      H-TAB

```

ESC "B" +n₁+n₂+...+n_k+0

Setting Vertical Tab Positions

Code: <1B>_H <42>_H <n₁> <n₂> ... <n_k> <00>_H
 or <27>₁₀ <66>₁₀ <n₁> <n₂> ... <n_k>
 <0>₁₀

BASIC Syntax: CHR\$(&H1B); "B"; CHR\$(n₁); CHR\$(n₂); ... ;
 CHR\$(n_k); CHR\$(0); or CHR\$(27); "B"; CHR\$(
 n₁); CHR\$(n₂); ... ; CHR\$(n_k); CHR\$(0);
 (1 ≤ n ≤ 255, 1 ≤ k ≤ 16)

Function: This code is used to set the vertical tab positions.

- A vertical tab position = the amount of current line spacing × the number of lines (n_k)
- Vertical tab positions are stored as absolute positions; therefore, they will not change even if the amount of line spacing is changed.
- Vertical tab positions should be set in the order of increasing values. If they are not, only the positions in the correct order will be set, and the rest will be ignored. Input the NUL code (<00>_H, <0>₁₀) to terminate the setting operation.
- When the VT code is entered, the paper is fed to the next vertical tab position, and printing is resumed.

Example: Setting the vertical tabs at 3rd, 7th, and 15th lines.

[Program]

```
10 REM VERTICAL TABULATION SET
20 LPRINT CHR$(27);"B";CHR$(3);CHR$(7);CHR$(15);CHR$(0)
```

VT

Executing Vertical Tabs

Code: <0B>_H or <11>₁₀
BASIC Syntax: CHR\$(&HB); or CHR\$(11);

Function: When this code is entered, all the data in the print buffer are printed, and the paper is then fed to the set vertical tab position for further printing.

- When vertical tabs have not been set, this code functions in the same manner as the LF code.
- The VT code cancels the Enlarged mode previously set with the SO code.
- When only one vertical tab has been set, the paper is fed to that vertical position or to the top of the next page when the VT code is entered.

Example 1: Printing with the vertical tabs set at the 5th, 8th, 13th and 18th lines.

[Program]

```
10 REM VERTICAL TABULATION
20 LPRINT "----- Start line -----"
30 LPRINT CHR$(27);"B";CHR$(5);CHR$(8);CHR$(13);CHR$(18);CHR$(0);
40 LPRINT CHR$(11);"----- U-TAB 5th line -----"
50 LPRINT CHR$(11);"----- U-TAB 8th line -----"
60 LPRINT CHR$(11);"----- U-TAB 13th line -----"
70 LPRINT CHR$(11);"----- U-TAB 18th line -----"
80 END
```

VT

Executing Vertical Tabs

[Printout]

----- Start line -----

----- U-TAB 5th line -----

----- U-TAB 8th line -----

----- U-TAB 13th line -----

----- U-TAB 18th line -----

VT

Executing Vertical Tabs

Example 2: Printing on two pages with the page length set to 7 lines, and the vertical tabs at the 1st and 6th lines.

[Program]

```

10 REM VERTICAL TABULATION
20 LPRINT CHR$(27);"C";CHR$(7);
30 LPRINT CHR$(27);"B";CHR$(1);CHR$(6);CHR$(0);
40 LPRINT CHR$(11);"----- U-TAB   line 1 -----"
50 LPRINT CHR$(11);"----- U-TAB   line 6 -----"
60 LPRINT CHR$(11);"----- U-TAB   line 1 -----"
70 LPRINT CHR$(11);"----- U-TAB   line 6 -----"
80 END

```

[Printout]

```

----- U-TAB   line 1 -----

----- U-TAB   line 6 -----

----- U-TAB   line 1 -----

----- U-TAB   line 6 -----

```

2. COLOR CONTROL CODES

ESC "V"+n

Setting Character Colors

Code: $\langle 1B \rangle_H \langle 56 \rangle_H \langle n \rangle$ or $\langle 27 \rangle_{10} \langle 86 \rangle_{10} \langle n \rangle$
BASIC Syntax: CHR\$(&H1B); "V"; CHR\$(n); or CHR\$(27);
"V"; CHR\$(n);
($0 \leq n \leq 7$)

Function: This code is used to set the color(s) of the characters.

- One byte is used to specify the color (n). Printing will be executed in the specified color.

n	Hexadecimal notation	Decimal notation	Color
0	30	48	Black
1	31	49	Red
2	32	50	Green
3	33	51	Yellow
4	34	52	Blue
5	35	53	Magenta
6	36	54	Cyan
7	37	55	White

- The color is set to black at power on.
- When the value of n is less than 0 or greater than 7, this code will be ignored, and the color will remain at the previously set color.

ESC "V"+n

Setting Character Colors

Example: Printing in different colors.

[Program]

```

100 REM COLOR DESIGNATION
110 LPRINT CHR$(27);"V";CHR$(%H33);
120 LPRINT "Yellow      12345 ABCDE <=>?"
130 LPRINT CHR$(27);"V";CHR$(%H35);
140 LPRINT "Magenta     12345 ABCDE <=>?"
150 LPRINT CHR$(27);"V";CHR$(%H36);
160 LPRINT "Cyan        12345 ABCDE <=>?"
170 LPRINT CHR$(27);"V";CHR$(%H31);
180 LPRINT "Red         12345 ABCDE <=>?"
190 LPRINT CHR$(27);"V";CHR$(%H32);
200 LPRINT "Green       12345 ABCDE <=>?"
210 LPRINT CHR$(27);"V";CHR$(%H34);
220 LPRINT "Blue        12345 ABCDE <=>?"
230 LPRINT CHR$(27);"V";CHR$(%H30);
240 LPRINT "Black      12345 ABCDE <=>?"
250 END

```

[Printout]

```

Magenta     12345 ABCDE <=>?
Cyan        12345 ABCDE <=>?
Red         12345 ABCDE <=>?
Green       12345 ABCDE <=>?
Blue        12345 ABCDE <=>?
Black      12345 ABCDE <=>?

```

ESC "g" +n

Setting Background Colors

Code: <1B>_H <67>_H <n> or <27>₁₀ <103>₁₀ <n>
BASIC Syntax: CHR\$(&H1B); "g"; CHR\$(n); or CHR\$(27); "g";
 CHR\$(n);
 (0 ≤ n ≤ 7)

Function: This code is used to set background colors.

- One byte is used to specify the color (n). The background will be printed in the specified color. The values of n are the same as those for specifying the color of the characters. (Refer to the ESC "V" + n code described previously.)
- The background color is set to white at power on.
- When the value of n is less than 0 or greater than 7, this code will be ignored.

Example 1: Printing the background in seven different colors.

[Program]

```
100 REM BACKGROUND COLOR
110 LPRINT CHR$(27);"g";CHR$(&H37);
120 LPRINT "Black      ";CHR$(27);"g";CHR$(&H30);
130 LPRINT "
140 LPRINT CHR$(27);"g";CHR$(&H37);
150 LPRINT "Red          ";CHR$(27);"g";CHR$(&H31);
160 LPRINT "
170 LPRINT CHR$(27);"g";CHR$(&H37);
180 LPRINT "Green       ";CHR$(27);"g";CHR$(&H32);
190 LPRINT "
200 LPRINT CHR$(27);"g";CHR$(&H37);
210 LPRINT "Yellow      ";CHR$(27);"g";CHR$(&H33);
220 LPRINT "
230 LPRINT CHR$(27);"g";CHR$(&H37);
240 LPRINT "Blue        ";CHR$(27);"g";CHR$(&H34);
250 LPRINT "
260 LPRINT CHR$(27);"g";CHR$(&H37);
270 LPRINT "Magenta     ";CHR$(27);"g";CHR$(&H35);
280 LPRINT "
290 LPRINT CHR$(27);"g";CHR$(&H37);
300 LPRINT "Cyan        ";CHR$(27);"g";CHR$(&H36);
310 LPRINT "
320 LPRINT CHR$(27);"g";CHR$(&H37);
330 LPRINT "White      "
340 LPRINT "
350 END
```

ESC "g" +n

Setting Background Color

[Printout]

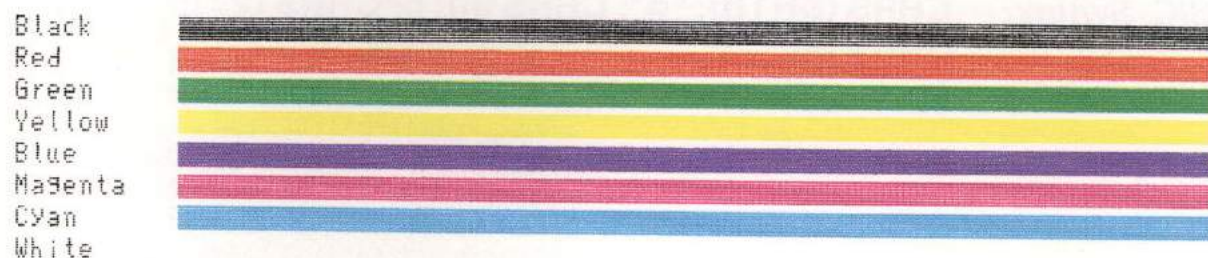

Example 2: Printing the background in different colors and the characters in white.

[Program]

```

100 REM BACKGROUND COLOR
110 LPRINT CHR$(27);CHR$(&H30);
120 LPRINT CHR$(27);"3";CHR$(&H30);
130 GOSUB 270
140 LPRINT CHR$(27);"3";CHR$(&H31);
150 GOSUB 270
160 LPRINT CHR$(27);"3";CHR$(&H32);
170 GOSUB 270
180 LPRINT CHR$(27);"3";CHR$(&H33);
190 GOSUB 270
200 LPRINT CHR$(27);"3";CHR$(&H34);
210 GOSUB 270
220 LPRINT CHR$(27);"3";CHR$(&H35);
230 GOSUB 270
240 LPRINT CHR$(27);"3";CHR$(&H36);
250 GOSUB 270
260 END
270 REM subroutine
280 LPRINT "
290 LPRINT CHR$(27);"U";CHR$(&H37);
300 LPRINT "      BACKGROUND      COLOR
310 LPRINT "
320 LPRINT CHR$(27);"3";CHR$(&H37);
330 LPRINT " "
340 RETURN

```

ESC "g" +n

Setting Background Color

[Printout]



Example 3: Printing the background in different colors and the characters in the Enlarged mode.

[Program]

```

100 REM BACKGROUND COLOR
110 LPRINT CHR$(27);CHR$(&H30);
120 LPRINT CHR$(27);"9";CHR$(&H30);
130 GOSUB 270
140 LPRINT CHR$(27);"9";CHR$(&H31);
150 GOSUB 270
160 LPRINT CHR$(27);"9";CHR$(&H32);
170 GOSUB 270
180 LPRINT CHR$(27);"9";CHR$(&H33);
190 GOSUB 270
200 LPRINT CHR$(27);"9";CHR$(&H34);
210 GOSUB 270
220 LPRINT CHR$(27);"9";CHR$(&H35);
230 GOSUB 270
240 LPRINT CHR$(27);"9";CHR$(&H36);
250 GOSUB 270
260 END

```

ESC "g" +n

Setting Background Color

```
270 REM subroutine
280 LPRINT CHR$(27);"W";CHR$(1);
290 LPRINT " "
300 LPRINT CHR$(27);"U";CHR$(8H37);
310 LPRINT " BACKGROUND COLOR "
320 LPRINT " "
330 LPRINT CHR$(27);"g";CHR$(8H37);
340 LPRINT " "
350 LPRINT CHR$(27);"W";CHR$(0);
360 RETURN
```

[Printout]



3. CHARACTER DESIGN CONTROL CODES

ESC "d"+n

Solarized Mode

Code: $\langle 1B \rangle_H \langle 64 \rangle_H \langle n \rangle$ or $\langle 27 \rangle_{10} \langle 100 \rangle_{10} \langle n \rangle$
BASIC Syntax: CHR\$(&H1B); "d"; CHR\$(n); or CHR\$(27); "d";
CHR\$(n);
(n=0 or 1)

Function: When this code is entered, with n=1, printing will be executed in the Solarized mode.

- When n=0, printing is in the Standard mode.
- The value of n has priority over the No. 6 selector of the DIP switch.

Example: Printing alternately in black and white for two lines (see next page).

ESC "d"+n**Solarized Mode****[Program]**

```

100 REM BLACK & WHITE
110 LPRINT CHR$(27);"d";CHR$(0);
120 FOR I=1 TO 4
130   LPRINT CHR$(27);"X";CHR$(3);
140   FOR J=1 TO 3
150     LPRINT CHR$(%H00);CHR$(%H00);CHR$(%H00);
160   NEXT J
170 NEXT I
180 LPRINT CHR$(27);"d";CHR$(1);
190 FOR I=1 TO 4
200   LPRINT CHR$(27);"X";CHR$(3);
210   FOR J=1 TO 3
220     LPRINT CHR$(%H00);CHR$(%H00);CHR$(%H00);
230   NEXT J
240 NEXT I
250 LPRINT CHR$(27);"d";CHR$(1);
260 FOR I=1 TO 4
270   LPRINT CHR$(27);"X";CHR$(3);
280   FOR J=1 TO 3
290     LPRINT CHR$(%HFF);CHR$(%HFF);CHR$(%HFF);
300   NEXT J
310 NEXT I
320 LPRINT CHR$(27);"d";CHR$(0);
330 FOR J=1 TO 4
340   LPRINT CHR$(27);"X";CHR$(3);
350   FOR K=1 TO 3
360     LPRINT CHR$(%HFF);CHR$(%HFF);CHR$(%HFF);
370   NEXT K
380 NEXT J
390 END

```

[Printout]

==

SO

Shift Out — Setting Enlarged Mode with Automatic Self-Cancellation

Code: <OE>_H or <14>₁₀
BASIC Syntax: CHR\$ (&HE); or CHR\$ (14);

Function: When this code is entered, all the data following it are printed in the Enlarged mode (twice the standard size horizontally). However, this mode is automatically cancelled after a line feed.

- The SO code can also be cancelled with the DC4 or ESC "W" + n codes or any other code with a line feed function.

Example 1: Printing alternately in the Enlarged and Standard modes.

[Program]

```
10 REM ENLARGED MODE
20 FOR I=1 TO 2
30   LPRINT CHR$(14);"ENLARGED   12345ABCDE<>=?"
40   LPRINT "STANDARD 12345ABCDE<>=?"
50 NEXT I
60 END
```

[Printout]

```
ENLARGED           1 2 3 4 5 A B C D E < > = ?
STANDARD 12345ABCDE<>=?
ENLARGED           1 2 3 4 5 A B C D E < > = ?
STANDARD 12345ABCDE<>=?
```

SO

Shift Out — Setting Enlarged Mode with Automatic Self-Cancellation

Example 2: Printing enlarged characters in different colors.

[Program]

```

100 REM ENLARGED MODE & COLOR
110 LPRINT CHR$(14);CHR$(27);"U";CHR$(&H33);
120 LPRINT "ENLARGED Yellow 12345 ABCDE <=>?"
130 LPRINT CHR$(14);CHR$(27);"U";CHR$(&H35);
140 LPRINT "ENLARGED Magenta 12345 ABCDE <=>?"
150 LPRINT CHR$(14);CHR$(27);"U";CHR$(&H36);
160 LPRINT "ENLARGED Cyan 12345 ABCDE <=>?"
170 LPRINT CHR$(14);CHR$(27);"U";CHR$(&H31);
180 LPRINT "ENLARGED Red 12345 ABCDE <=>?"
190 LPRINT CHR$(14);CHR$(27);"U";CHR$(&H32);
200 LPRINT "ENLARGED Green 12345 ABCDE <=>?"
210 LPRINT CHR$(14);CHR$(27);"U";CHR$(&H34);
220 LPRINT "ENLARGED Blue 12345 ABCDE <=>?"
230 LPRINT CHR$(14);CHR$(27);"U";CHR$(&H30);
240 LPRINT "ENLARGED Black 12345 ABCDE <=>?"
250 END

```

[Printout]

ENLARGED	Magenta	12345	ABCDE	<=>?
ENLARGED	Cyan	12345	ABCDE	<=>?
ENLARGED	Red	12345	ABCDE	<=>?
ENLARGED	Green	12345	ABCDE	<=>?
ENLARGED	Blue	12345	ABCDE	<=>?
ENLARGED	Black	12345	ABCDE	<=>?

ESC SO

Setting Enlarged Mode with Automatic Self-Cancellation

Code: $\langle 1B \rangle_H \langle 0E \rangle_H$ or $\langle 27 \rangle_{10} \langle 14 \rangle_{10}$
BASIC Syntax: CHR\$(&H1B); CHR\$(&HE); or CHR\$(27);
 CHR\$(14);

Function: Same as the SO code.

Example 1: Printing alternately in the Enlarged and Standard modes.

[Program]

```
10 REM ENLARGED MODE
20 FOR I=1 TO 2
30   LPRINT CHR$(27);CHR$(14);"ENLARGED   12345ABCDE<>=?"
40   LPRINT "STANDARD 12345ABCDE<>=?"
50 NEXT I
60 END
```

[Printout]

```
ENLARGED           1 2 3 4 5 A B C D E < > = ?
STANDARD 12345ABCDE<>=?
ENLARGED           1 2 3 4 5 A B C D E < > = ?
STANDARD 12345ABCDE<>=?
```

ESC SO

Setting Enlarged Mode with Automatic Self-Cancellation

Example 2: Printing enlarged characters in different colors.

[Program]

```

100 REM ENLARGED MODE & COLOR
110 LPRINT CHR$(27);CHR$(14);CHR$(27);"U";CHR$(&H33);
120 LPRINT "ENLARGED Yellow 12345 ABCDE <=>?"
130 LPRINT CHR$(27);CHR$(14);CHR$(27);"U";CHR$(&H35);
140 LPRINT "ENLARGED Magenta 12345 ABCDE <=>?"
150 LPRINT CHR$(27);CHR$(14);CHR$(27);"U";CHR$(&H36);
160 LPRINT "ENLARGED Cyan 12345 ABCDE <=>?"
170 LPRINT CHR$(27);CHR$(14);CHR$(27);"U";CHR$(&H31);
180 LPRINT "ENLARGED Red 12345 ABCDE <=>?"
190 LPRINT CHR$(27);CHR$(14);CHR$(27);"U";CHR$(&H32);
200 LPRINT "ENLARGED Green 12345 ABCDE <=>?"
210 LPRINT CHR$(27);CHR$(14);CHR$(27);"U";CHR$(&H34);
220 LPRINT "ENLARGED Blue 12345 ABCDE <=>?"
230 LPRINT CHR$(27);CHR$(14);CHR$(27);"U";CHR$(&H30);
240 LPRINT "ENLARGED Black 12345 ABCDE <=>?"
250 END

```

[Printout]

ENLARGED	Magenta	12345	ABCDE	<=>?
ENLARGED	Cyan	12345	ABCDE	<=>?
ENLARGED	Red	12345	ABCDE	<=>?
ENLARGED	Green	12345	ABCDE	<=>?
ENLARGED	Blue	12345	ABCDE	<=>?
ENLARGED	Black	12345	ABCDE	<=>?

DC4

Device Control 4 – Cancelling Enlarged Mode with Automatic Self-Cancellation

Code: <14>_H or <20>₁₀
BASIC Syntax: CHR\$(&H14); or CHR\$(20);

Function: This code is used to cancel the Enlarged mode set with the SO or ESC SO code.

- The Enlarged mode set with the ESC"W" or ESC"! "codes cannot be cancelled with this code.

Example: Cancelling the Enlarged mode with the DC4 code.

[Program]

```
10 REM DEVICE CONTROL 4
20 LPRINT CHR$(14);"ENLARGED ";CHR$(20);"STANDARD ";CHR$(14);"ENLARGED"
30 LPRINT "STANDARD"
40 END
```

[Printout]

```
ENLARGED STANDARD ENLARGED
STANDARD
```

ESC "W" +n

Setting Enlarged Mode

Code: <1B>_H <57>_H <n> or <27>₁₀ <87>₁₀ <n>
BASIC Syntax: CHR\$(&H1B); "W"; CHR\$(n); or CHR\$(27);
 "W"; CHR\$(n);
 (n=0 or 1)

Function: When this code is entered with n=1, all the data following it are printed in the Enlarged mode. Unlike the Enlarged mode with automatic self-cancellation, this mode will not be cancelled by a line feed.

- When n=1, the Enlarged mode is set, and is cancelled when n=0.

Example: Printing two lines in the Enlarged mode and then cancelling the Enlarged mode.

[Program]

```
100 REM ENLARGED MODE
110 LPRINT CHR$(27);"W";CHR$(1);
120 FOR I=1 TO 2
130   LPRINT "ENLARGED      ";CHR$(13);
140   LPRINT "                12345ABCDE<>=?"
150 NEXT I
160 LPRINT CHR$(27);"W";CHR$(0);
170 LPRINT "STANDARD      ";CHR$(13);
180 LPRINT "                12345ABCDE<>=?"
190 END
```

[Printout]

```
ENLARGED      12345ABCDE<>=?
ENLARGED      12345ABCDE<>=?
STANDARD      12345ABCDE<>=?
```

ESC "!" + n**Setting Enlarged Mode**

Code: <1B>_H <21>_H <n> or <27>₁₀ <33>₁₀ <n>
BASIC Syntax: CHR\$(&H1B); "!" ; CHR\$(n); or CHR\$(27); "!" ;
 CHR\$(n);
 (n = <20>_H or <32>₁₀)

Function: When this code is entered with n = <20>_H, all the data following it are printed in the Enlarged mode.

- Values other than n = <20>_H are ignored.
- This code, with n = <20>_H is the same as the ESC "W" + n code with n = 1.
- The ESC "!" + n code with n = <20>_H can be cancelled with the ESC "W" + n code (n = 0).

Example: Printing in the Enlarged mode and then the Standard mode.

[Program]

```
100 REM PRINT MODE DESIGNATION
110 LPRINT CHR$(27);"!"CHR$(&H20);
120 FOR I=1 TO 2
130   LPRINT "ENLARGED   ";
140   LPRINT "12345ABCDE<=>?"
150 NEXT I
160 LPRINT CHR$(27);"W"CHR$(0);
170 LPRINT "STANDARD   ";
180 LPRINT "12345ABCDE<=>?"
190 END
```

[Printout]

```
ENLARGED      1 2 3 4 5 A B C D E < = > ?
ENLARGED      1 2 3 4 5 A B C D E < = > ?
STANDARD      1 2 3 4 5 A B C D E < = > ?
```

ESC "G"

Setting Bold Mode

Code: <1B>_H <47>_H or <27>₁₀ <71>₁₀
BASIC Syntax: CHR\$ (&H1B); "G"; or CHR\$ (27); "G";

Function: When this code is entered, the printer is set to the **Bold mode**.

- The printer can also be set to the Bold mode by using the BOLD switch on its rear panel.
- The BOLD switch takes priority over this code.

Example 1: Printing the second line in bold characters.

[Program]

```
100 REM NORMAL AND BOLD
110 LPRINT "!! normal print !!"
120 LPRINT CHR$(27);"G";
130 LPRINT "!! bold print !!"
140 LPRINT CHR$(27);"H";
150 LPRINT "!! normal print !!"
160 END
```

[Printout]

```
!! normal print !!
!! bold print !!
!! normal print !!
```

ESC "G"

Setting Bold Mode

Example 2: Printing bold characters in different colors and in the Enlarged mode.

[Program]

```
100 REM NORMAL AND BOLD
110 LPRINT "normal Print "
120 GOSUB 180
130 LPRINT "bold Print"
140 LPRINT CHR$(27);"G";
150 GOSUB 180
160 LPRINT CHR$(27);"H";
170 END
180 FOR I=0 TO 1
190   LPRINT CHR$(27);"W";CHR$(I);
200   FOR J=&H30 TO &H37
210     LPRINT CHR$(27);"U";CHR$(J);
220     FOR K=&H30 TO &H4F
230       LPRINT CHR$(K);
240     NEXT K
250   LPRINT
260 NEXT J
270 LPRINT
280 NEXT I
290 LPRINT CHR$(27);"W";CHR$(0);
300 LPRINT CHR$(27);"U";CHR$(&H30);
310 RETURN
```

ESC "G"

Setting Bold Mode

[Printout]

normal Print

```

0123456789:;<=>?@ABCDEFGHIJKLMN0
0123456789:;<=>?@ABCDEFGHIJKLMN0
0123456789:;<=>?@ABCDEFGHIJKLMN0
0123456789:;<=>?@ABCDEFGHIJKLMN0
0123456789:;<=>?@ABCDEFGHIJKLMN0
0123456789:;<=>?@ABCDEFGHIJKLMN0
0123456789:;<=>?@ABCDEFGHIJKLMN0

```

```

0123456789:;<=>?@ABCDEFGHIJKLMN0
0123456789:;<=>?@ABCDEFGHIJKLMN0
0123456789:;<=>?@ABCDEFGHIJKLMN0
0123456789:;<=>?@ABCDEFGHIJKLMN0
0123456789:;<=>?@ABCDEFGHIJKLMN0
0123456789:;<=>?@ABCDEFGHIJKLMN0
0123456789:;<=>?@ABCDEFGHIJKLMN0

```

bold Print

```

0123456789:;<=>?@ABCDEFGHIJKLMN0
0123456789:;<=>?@ABCDEFGHIJKLMN0
0123456789:;<=>?@ABCDEFGHIJKLMN0
0123456789:;<=>?@ABCDEFGHIJKLMN0
0123456789:;<=>?@ABCDEFGHIJKLMN0
0123456789:;<=>?@ABCDEFGHIJKLMN0
0123456789:;<=>?@ABCDEFGHIJKLMN0

```

```

0123456789:;<=>?@ABCDEFGHIJKLMN0
0123456789:;<=>?@ABCDEFGHIJKLMN0
0123456789:;<=>?@ABCDEFGHIJKLMN0
0123456789:;<=>?@ABCDEFGHIJKLMN0
0123456789:;<=>?@ABCDEFGHIJKLMN0
0123456789:;<=>?@ABCDEFGHIJKLMN0
0123456789:;<=>?@ABCDEFGHIJKLMN0

```

ESC "H"

Cancelling Bold Mode

Code: <1B>_H <48>_H or <27>₁₀ <72>₁₀
BASIC Syntax: CHR\$(&H1B); "H"; or CHR\$(27); "H";

Function: This code is used to cancel the Bold mode set with the ESC "G" code.

Example: Printing only the second line in the Bold mode.

[Program]

```
100 REM NORMAL AND BOLD
110 LPRINT "!! normal Print !!"
120 LPRINT CHR$(27);"G";
130 LPRINT "!! bold Print !!"
140 LPRINT CHR$(27);"H";
150 LPRINT "!! normal Print !!"
160 END
```

[Printout]

```
!! normal Print !!
!! bold Print !!
!! normal Print !!
```

ESC " - " +n**Setting Underlined Mode**

Code: <1B>_H <2D>_H <n> or <27>₁₀ <45>₁₀ <n>
BASIC Syntax: CHR\$ (&H1B); "-" ; CHR\$ (n); or CHR\$ (27);
 "-" ; CHR\$ (n);
 (n=0 or 1)

Function: When this code is entered with n=1, printing is executed in the Underlined mode.

- All the data following this code (including spaces) are underlined.
- The Underline mode is cancelled with this code when n=0. It cannot be cancelled with the CAN code.

Example 1: Printing in the Underlined mode.

[Program]

```
10 REM UNDERLINED PRINT MODE
20 LPRINT CHR$(27); "-" ; CHR$(0); " ABC "; CHR$(27); "-" ; CHR$(1); " XYZ ";
30 LPRINT CHR$(27); "-" ; CHR$(0); " 123 "; CHR$(27); "-" ; CHR$(1); " <=> "
40 END
```

[Printout]

ABC XYZ 123 <=>

Example 2: Printing enlarged characters in the Underlined mode.

[Program]

```
10 REM UNDERLINED PRINT MODE
20 LPRINT CHR$(27); "-" ; CHR$(1); " STANDARD ";
30 LPRINT CHR$(27); CHR$(14);
40 LPRINT CHR$(27); "-" ; CHR$(1); " ENLARGED ";
50 END
```

[Printout]

STANDARD ENLARGED

ESC " _ " +n**Setting Underlined Mode**

Example 3: Printing characters in different colors in the Underlined mode.

[Program]

```

100 REM UNDERLINED PRINT MODE
110 LPRINT CHR$(27);"U";CHR$(&H30);CHR$(27);"-";CHR$(1);
120 LPRINT "Black";CHR$(27);"-";CHR$(0);" ";
130 LPRINT CHR$(27);"U";CHR$(&H31);CHR$(27);"-";CHR$(1);
140 LPRINT "Red";CHR$(27);"-";CHR$(0);" ";
150 LPRINT CHR$(27);"U";CHR$(&H32);CHR$(27);"-";CHR$(1);
160 LPRINT "Green";CHR$(27);"-";CHR$(0);" ";
170 LPRINT CHR$(27);"U";CHR$(&H33);CHR$(27);"-";CHR$(1);
180 LPRINT "Yellow";CHR$(27);"-";CHR$(0);" ";
190 LPRINT CHR$(27);"U";CHR$(&H34);CHR$(27);"-";CHR$(1);
200 LPRINT "Blue";CHR$(27);"-";CHR$(0);" ";
210 LPRINT CHR$(27);"U";CHR$(&H35);CHR$(27);"-";CHR$(1);
220 LPRINT "Magenta";CHR$(27);"-";CHR$(0);" ";
230 LPRINT CHR$(27);"U";CHR$(&H36);CHR$(27);"-";CHR$(1);
240 LPRINT "Cyan"
250 END

```

[Printout]

Black Red Green Yellow Blue Magenta Cyan

4. GRAPHIC IMAGE CONTROL CODES

ESC "K" +n₁ +n₂

Setting Graphic Image Mode

Code: <1B>_H <4B>_H <n₁> <n₂> or <27>₁₀
<75>₁₀ <n₁> <n₂>

BASIC Syntax: CHR\$(&H1B); "K"; CHR\$(n₁); CHR\$(n₂); or
CHR\$(27); "K"; CHR\$(n₁); CHR\$(n₂);
(0 ≤ n₁, n₂ ≤ 256)

Function: When this code is entered, data (n₁ and n₂ specify the number of data) are printed in the Graphic Image mode.

- The relationship between the graphic image data and the print head is shown as below.

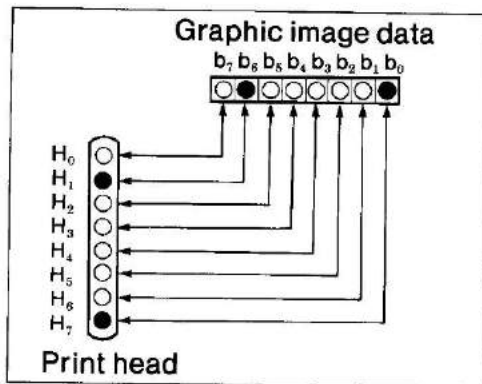

Fig. 1

As shown in Fig. 1, the graphic image data and the print head correspond with each other on a one-to-one basis. If a bit is 1, the print head fires, and if it is 0, the print head does not fire. In Fig. 1, b₀ and b₆ contain 1 bits (●=1, ○=0). <01000001>₂ in the hexadecimal notation is <41>_H. Therefore, when you send the graphic image data <41>_H in the Graphic image mode, H₁ and H₇ of the print head is fired.

- Up to 560 bytes of graphic image data can be printed per line. Excess data are ignored.
- The values for n₁ and n₂ can be derived as follows:

$$n_1 = \text{Remainder of } \frac{\text{Number of data}}{256}$$

$$n_2 = \text{Integer part of the quotient of } \frac{\text{Number of data}}{256}$$

ESC "K" +n₁ +n₂**Setting Graphic Image Mode**

Example: The number of graphic image data bytes is 300.

```

1 ..... n2 = <01>H or <1>10
256 300
256
44 ..... n1 = <2C>H or <44>10

```

Example 1: First setting the number of graphic image data to 300 bytes and printing graphic image data <81>_H and then setting the number of graphic image data to 400 bytes and printing graphic image data <FF>_H.

[Program]

```

100 REM GRAPHIC IMAGE PRINT
110 REM Graphic image data number=300 & 400
120 LPRINT CHR$(27);"K";CHR$(300 MOD 256);CHR$(INT(300/256));
130 FOR I=1 TO 300
140   LPRINT CHR$(&H81);
150 NEXT I
160 LPRINT:LPRINT
170 LPRINT CHR$(27);"K";CHR$(400 MOD 256);CHR$(INT(400/256));
180 FOR J=1 TO 400
190   LPRINT CHR$(&HFF);
200 NEXT J
210 END

```

[Printout]

ESC "K" +n₁ +n₂**Setting Graphic Image Mode**

Example 2: Setting the number of graphic image data to 200, and printing the graphic image data <FF>_H at the beginning and the end, and printing the graphic image data <01>_H to <0F>_H in between.

[Program]

```

100 REM GRAPHIC IMAGE PRINT
110 REM number of data 200
120 FOR I=1 TO 9
130   LPRINT CHR$(&H30+I); "  ";
140   N=200
150   LPRINT CHR$(27);"K";CHR$(N MOD 256);CHR$(INT(N/256));
160   LPRINT CHR$(&HFF);
170   FOR J=2 TO N-1
180     LPRINT CHR$(I);
190   NEXT J
200   LPRINT CHR$(&HFF)
210 NEXT I
220 FOR I=10 TO 15
230   LPRINT CHR$(&H37+I); "  ";
240   N=200
250   LPRINT CHR$(27);"K";CHR$(N MOD 256);CHR$(INT(N/256));
260   LPRINT CHR$(&HFF);
270   FOR J=2 TO N-1
280     LPRINT CHR$(I);
290   NEXT J
300   LPRINT CHR$(&HFF)
310 NEXT I
320 END

```

[Printout]

1	
2	
3	
4	
5	
6	
7	
8	
9	
A	
B	
C	
D	
E	
F	

ESC "K" +n₁ +n₂

Setting Graphic Image Mode

Example 3: Setting the number of graphic image data to 300 bytes, and printing the graphic image data <55>_H in seven different colors.

[Program]

```

100 REM GRAPHIC IMAGE PRINT
110 REM number of data 300
120 FOR I=&H30 TO &H37
130   LPRINT CHR$(27);"V";CHR$(I);
140   N=300
150   LPRINT CHR$(27);"K";CHR$(N MOD 256);CHR$(INT(N/256));
160   FOR J=1 TO N
170     LPRINT CHR$(&H55);
180   NEXT J
190   LPRINT:LPRINT
200 NEXT I
210 END

```

[Printout]

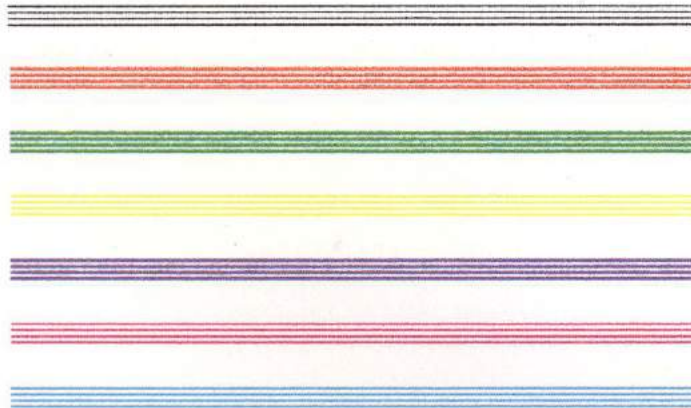

ESC "*" + m + n₁ + n₂**Setting Graphic Image Mode**

Code: <1B>_H <2A>_H <m> <n₁> <n₂> or <27>₁₀
<42>₁₀ <m> <n₁> <n₂>

BASIC Syntax: CHR\$(&H1B); "*" ; CHR\$(m); CHR\$(n₁); CHR\$(
(n₂); or CHR\$(27); "*" ; CHR\$(m); CHR\$(n₁);
CHR\$(n₂);
(m=0, 0 ≤ n₁, n₂ ≤ 255)

Function: When this code is entered with m=0, the data are printed in the Graphic Image mode.
Image mode.

- The ESC "*" + m + n₁ + n₂ code with m=0 is the same as the ESC "K" + n₁ + n₂ code, and the values for n₁ and n₂ can be derived in the same manner.
- The value of m can only be set to zero. Other values will be ignored.

Example 1: Setting the number of graphic image data to 300 and printing the graphic image data <55>_H. ("m" must equal zero.)

[Program]

```
100 REM GRAPHIC IMAGE PRINT
110 LPRINT " ESC *+m+n1+n2"
120 N=300
130 LPRINT CHR$(27);"*";CHR$(0);CHR$(N MOD 256);CHR$(INT(N/256));
140 FOR J=1 TO 300
150   LPRINT CHR$(55);
160 NEXT J
170 LPRINT
180 END
```

[Printout]

ESC *+m+n1+n2

ESC "*" +m+n₁+n₂**Setting Graphic Image Mode**

Example 2: Printing different amounts of graphic image data.

[Program]

```

100 REM GRAPHIC IMAGE PRINT
110 REM data number=350
120 N=350
130 LPRINT CHR$(27);"*";CHR$(0);CHR$(N MOD 256);CHR$(INT(N/256));
140 FOR I=1 TO N
150   LPRINT CHR$(I MOD 256);
160 NEXT I
170 LPRINT
180 END

```

[Printout]

Example 3: Printing Example 2 in various colors.

```

100 REM GRAPHIC IMAGE PRINT
110 REM data number=350
120 FOR I=&H30 TO &H37
130   LPRINT CHR$(27);"V";CHR$(I);
140   N=350
150   LPRINT CHR$(27);"*";CHR$(0);CHR$(N MOD 256);CHR$(INT(N/256));
160   FOR J=1 TO N
170     LPRINT CHR$(J MOD 256);
180   NEXT J
190   LPRINT:LPRINT
200 NEXT I
210 END

```



5. COLOR GRAPHIC IMAGE CONTROL CODES

ESC "X" +n

Setting Color Graphic Image Mode

Code: $\langle 1B \rangle_H \langle 58 \rangle_H \langle n \rangle$ or $\langle 27 \rangle_{10} \langle 88 \rangle_{10} \langle n \rangle$
BASIC Syntax: CHR\$(&H1B); "X"; CHR\$(n); or CHR\$(27); "X";
 CHR\$(n);
 ($1 \leq n \leq 80$)

Function: When this code is entered, printing is executed in the Color Graphic Image mode.

- Printing method is in the horizontal direction in units of bits. One bit corresponds to one dot, and the printer prints according to the value of the bits.
- n = number of output bytes and 1 byte = 8 bits byte = 8 bits
Therefore, actual number of dots printed = $n \times 8$
- Maximum of 80 bytes (or 640 dots) can be printed per line. In the Color graphic image mode, a line is called a dot line and it is not same as the lines in the other modes.
- How to set the color of each dot

A color is specified using the composite colors: red, green and blue. To print 8 dots (remember 8 dots = 8 bits or 1 byte), output data in the fixed order of 1 byte of red data, 1 byte of green data and 1 byte of blue data must be given. The table below shows how to specify each color.

Output data \ Dot Color	(R) Red	(G) Green	(B) Blue
Black	0	0	0
Red	1	0	0
Green	0	1	0
Blue	0	0	1
Cyan	0	1	1
Yellow	1	1	0
Magenta	1	0	1
White	1	1	1

- 0 and 1 indicate the bits of the output data.
- This table is for when the No. 6 selector of the DIP switch is set to ON (Standard mode) at power on. When it is set to OFF, (Solorized mode) the output data for black and white is as follows:

Black	1	1	1
White	0	0	0

For example, to print each dot of 1 byte of output data in different color, the following output data must be given.

ESC "X" + n

Setting Color Graphic Image Mode

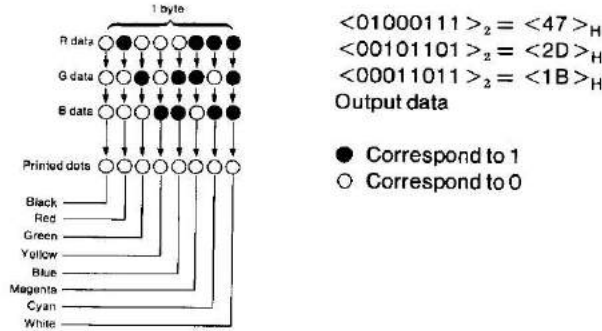

When you want to print more than 1 byte of output data, you must give output data for each byte.

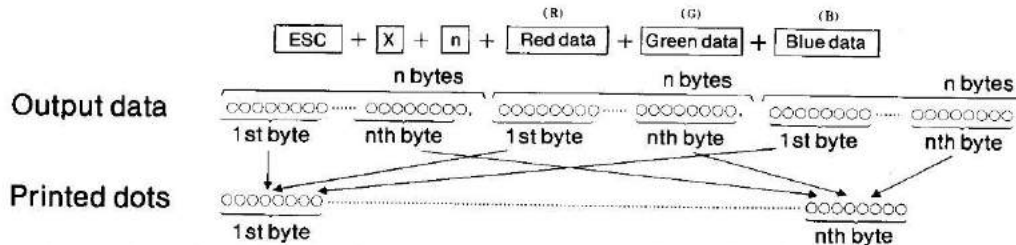

To print on the next dot line, you must use another ESC "X" + n code. However, there is the ESC "r" + n₁ + n₂ which lets you print on many dot lines. (Refer to the ESC "r" + n₁ + n₂ code.)

- The ESC "X" + n code must be used in pairs. In other words you must use even numbers of ESC "X" + n codes. If there are odd numbers of ESC "X" + n codes, the odd ESC "X" + n code will remain stored in the print buffer. However, this code can be executed with another ESC "X" + n (the second ESC "X" + n will be executed along with the first ESC "X" + n code), the color graphic image repeat code (ESC "r" + n₁ + n₂)*, the color graphic image dot line skip code (ESC "e" + n)*, or another command code (in this case, after the dots have been printed, the paper is fed 1 dot line).

* Refer to their respective sections for details.

- After an ESC "X" + n code has been executed, the printer is put into the previously set mode.

- Notes:
1. Nothing is printed when n=0.
 2. When the output data is over the value of n (for example, n=2 and there are 3 bytes of red data), the printer is put into the previously set mode.
 3. When there are no output data, the paper is fed 1 dot line.

Example 1: Printing the pattern shown below.

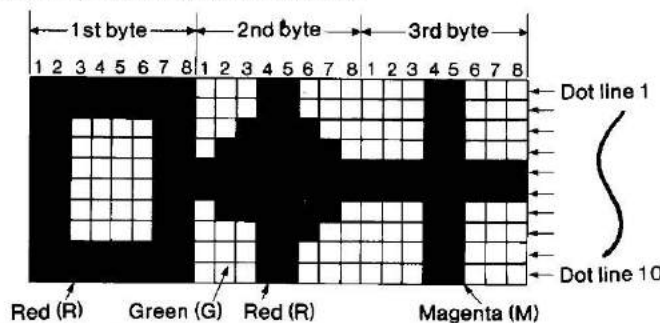

ESC "X" +n

Setting Color Graphic Image Mode

Code table (Hexadecimal notation)

R data			G data			B data			Number of Dot line
1st byte	2nd byte	3rd byte	1st byte	2nd byte	3rd byte	1st byte	2nd byte	3rd byte	
FF	18	FF	00	E7	E7	00	00	FF	Dot line 1
FF	18	FF	00	E7	E7	00	00	FF	Dot line 2
FF	3C	FF	3C	C3	E7	3C	00	FF	Dot line 3
FF	7E	FF	3C	81	E7	3C	00	FF	Dot line 4
FF	FF	FF	3C	00	00	3C	00	FF	Dot line 5
FF	FF	FF	3C	00	00	3C	00	FF	Dot line 6
FF	7E	FF	3C	81	E7	3C	00	FF	Dot line 7
FF	3C	FF	3C	C3	E7	3C	00	FF	Dot line 8
FF	18	FF	00	E7	E7	00	00	FF	Dot line 9
FF	18	FF	00	E7	E7	00	00	FF	Dot line 10

[Program]

```

100 REM COLOR GRAPHIC IMAGE
110 LPRINT CHR$(27);"X";CHR$(3);
120 LPRINT CHR$(%HFF);CHR$(%H18);CHR$(%HFF);CHR$(%H00);CHR$(%HE7);CHR$(%HE7);
130 LPRINT CHR$(%H00);CHR$(%H00);CHR$(%HFF);
140 LPRINT CHR$(27);"X";CHR$(3);
150 LPRINT CHR$(%HFF);CHR$(%H18);CHR$(%HFF);CHR$(%H00);CHR$(%HE7);CHR$(%HE7);
160 LPRINT CHR$(%H00);CHR$(%H00);CHR$(%HFF);
170 LPRINT CHR$(27);"X";CHR$(3);
180 LPRINT CHR$(%HFF);CHR$(%H3C);CHR$(%HFF);CHR$(%H3C);CHR$(%HC3);CHR$(%HE7);
190 LPRINT CHR$(%H3C);CHR$(%H00);CHR$(%HFF);
200 LPRINT CHR$(27);"X";CHR$(3);
210 LPRINT CHR$(%HFF);CHR$(%H7E);CHR$(%HFF);CHR$(%H3C);CHR$(%H81);CHR$(%HE7);
220 LPRINT CHR$(%H3C);CHR$(%H00);CHR$(%HFF);
230 LPRINT CHR$(27);"X";CHR$(3);
240 LPRINT CHR$(%HFF);CHR$(%HFF);CHR$(%HFF);CHR$(%H3C);CHR$(%H00);CHR$(%H00);
250 LPRINT CHR$(%H3C);CHR$(%H00);CHR$(%HFF);
260 LPRINT CHR$(27);"X";CHR$(3);
270 LPRINT CHR$(%HFF);CHR$(%HFF);CHR$(%HFF);CHR$(%H3C);CHR$(%H00);CHR$(%H00);
280 LPRINT CHR$(%H3C);CHR$(%H00);CHR$(%HFF);
290 LPRINT CHR$(27);"X";CHR$(3);
300 LPRINT CHR$(%HFF);CHR$(%H7E);CHR$(%HFF);CHR$(%H3C);CHR$(%H81);CHR$(%HE7);
310 LPRINT CHR$(%H3C);CHR$(%H00);CHR$(%HFF);
320 LPRINT CHR$(27);"X";CHR$(3);
330 LPRINT CHR$(%HFF);CHR$(%H3C);CHR$(%HFF);CHR$(%H3C);CHR$(%HC3);CHR$(%HE7);
340 LPRINT CHR$(%H3C);CHR$(%H00);CHR$(%HFF);
350 LPRINT CHR$(27);"X";CHR$(3);
360 LPRINT CHR$(%HFF);CHR$(%H18);CHR$(%HFF);CHR$(%H00);CHR$(%HE7);CHR$(%HE7);
370 LPRINT CHR$(%H00);CHR$(%H00);CHR$(%HFF);
380 LPRINT CHR$(27);"X";CHR$(3);
390 LPRINT CHR$(%HFF);CHR$(%H18);CHR$(%HFF);CHR$(%H00);CHR$(%HE7);CHR$(%HE7);
400 LPRINT CHR$(%H00);CHR$(%H00);CHR$(%HFF);
410 END

```

[Printout]

ESC "X" +n

Setting Color Graphic Image Mode

Example 2: Printing in all colors by changing color every four dot lines.

1st byte	2nd byte	3rd byte	4th byte	
				(Black) — Dot lines 1~4
				(Red) — Dot lines 5~8
				(Green) — Dot lines 9~12
				(Yellow) — Dot lines 13~16
				(Blue) — Dot lines 17~20
				(Magenta) — Dot lines 21~24
				(Cyan) — Dot lines 25~28
				(White) — Dot lines 29~32

[Program]

```

100 REM COLOR GRAPHIC IMAGE
110 FOR I=1 TO 4
120   LPRINT CHR$(27);"X";CHR$(4);
130   LPRINT CHR$(%H00);CHR$(%H00);CHR$(%H00);CHR$(%H00);
140   LPRINT CHR$(%H00);CHR$(%H00);CHR$(%H00);CHR$(%H00);
150   LPRINT CHR$(%H00);CHR$(%H00);CHR$(%H00);CHR$(%H00);
160 NEXT I
170 FOR I=1 TO 4
180   LPRINT CHR$(27);"X";CHR$(4);
190   LPRINT CHR$(%HFF);CHR$(%HFF);CHR$(%HFF);CHR$(%HFF);
200   LPRINT CHR$(%H00);CHR$(%H00);CHR$(%H00);CHR$(%H00);
210   LPRINT CHR$(%H00);CHR$(%H00);CHR$(%H00);CHR$(%H00);
220 NEXT I
230 FOR I=1 TO 4
240   LPRINT CHR$(27);"X";CHR$(4);
250   LPRINT CHR$(%H00);CHR$(%H00);CHR$(%H00);CHR$(%H00);
260   LPRINT CHR$(%HFF);CHR$(%HFF);CHR$(%HFF);CHR$(%HFF);
270   LPRINT CHR$(%H00);CHR$(%H00);CHR$(%H00);CHR$(%H00);
280 NEXT I
290 FOR I=1 TO 4
300   LPRINT CHR$(27);"X";CHR$(4);
310   LPRINT CHR$(%HFF);CHR$(%HFF);CHR$(%HFF);CHR$(%HFF);
320   LPRINT CHR$(%HFF);CHR$(%HFF);CHR$(%HFF);CHR$(%HFF);
330   LPRINT CHR$(%H00);CHR$(%H00);CHR$(%H00);CHR$(%H00);
340 NEXT I
350 FOR I=1 TO 4
360   LPRINT CHR$(27);"X";CHR$(4);
370   LPRINT CHR$(%H00);CHR$(%H00);CHR$(%H00);CHR$(%H00);
380   LPRINT CHR$(%H00);CHR$(%H00);CHR$(%H00);CHR$(%H00);
390   LPRINT CHR$(%HFF);CHR$(%HFF);CHR$(%HFF);CHR$(%HFF);
400 NEXT I
410 FOR I=1 TO 4
420   LPRINT CHR$(27);"X";CHR$(4);
430   LPRINT CHR$(%HFF);CHR$(%HFF);CHR$(%HFF);CHR$(%HFF);
440   LPRINT CHR$(%H00);CHR$(%H00);CHR$(%H00);CHR$(%H00);

```

ESC "X" +n

Setting Color Graphic Image Mode

```

450 LPRINT CHR$(8)CHR$(8)CHR$(8)CHR$(8);
460 NEXT I
470 FOR I=1 TO 4
480 LPRINT CHR$(27);"X";CHR$(4);
490 LPRINT CHR$(0)CHR$(0)CHR$(0)CHR$(0);
500 LPRINT CHR$(8)CHR$(8)CHR$(8)CHR$(8);
510 LPRINT CHR$(8)CHR$(8)CHR$(8)CHR$(8);
520 NEXT I
530 FOR I=1 TO 4
540 LPRINT CHR$(27);"X";CHR$(4);
550 LPRINT CHR$(8)CHR$(8)CHR$(8)CHR$(8);
560 LPRINT CHR$(8)CHR$(8)CHR$(8)CHR$(8);
570 LPRINT CHR$(8)CHR$(8)CHR$(8)CHR$(8);
580 NEXT I
590 END

```

[Printout]



Example 3: Printing in red, green and blue; each color printed for 10 dot lines.

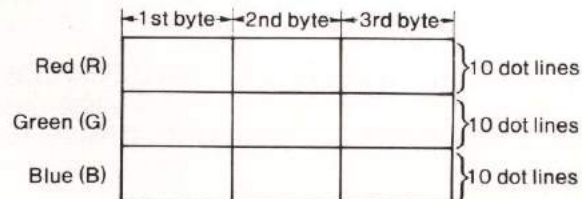

[Program]

```

100 REM COLOR GRAPHIC IMAGE MODE
110 LPRINT CHR$(27);"r";CHR$(10);CHR$(3); ← Color graphic image repeat code.
120 LPRINT CHR$(8)CHR$(8)CHR$(8);
130 LPRINT CHR$(0)CHR$(0)CHR$(0);
140 LPRINT CHR$(0)CHR$(0)CHR$(0);
150 LPRINT CHR$(27);"r";CHR$(10);CHR$(3);
160 LPRINT CHR$(0)CHR$(0)CHR$(0);
170 LPRINT CHR$(8)CHR$(8)CHR$(8);
180 LPRINT CHR$(0)CHR$(0)CHR$(0);
190 LPRINT CHR$(27);"r";CHR$(10);CHR$(3);
200 LPRINT CHR$(0)CHR$(0)CHR$(0);
210 LPRINT CHR$(0)CHR$(0)CHR$(0);
220 LPRINT CHR$(8)CHR$(8)CHR$(8);
230 END

```

[Printout]



ESC "r" + n₁ + n₂

Executing Color Graphic Image Repeat

Code: <1B>_H <72>_H <n₁> <n₂> or
 <27>₁₀ <114>₁₀ <n₁> <n₂>

BASIC Syntax: CHR\$ (&H1B); "r"; CHR\$ (n₁); CHR\$ (n₂); or
 CHR\$ (27); "r"; CHR\$ (n₁); CHR\$ (n₂);
 (0 ≤ n₁ ≤ 255, 1 ≤ n₂ ≤ 80)

Function: When this code is entered, the printer is put into the Color Graphic Image mode, and n₂ bytes of output data are printed n₁ dot lines.

- n₂ is same as n in the ESC "X" + n code.
- When n₁ = 0, this code is the same as the ESC "X" + n code.
- This function has priority over the page length and perforation skip functions.
- After the ESC "r" + n₁ + n₂ code has been executed, the printer is put into the previously set mode.

Example : Printing in seven different colors in the horizontal direction (3 bytes percolor), and in the vertical direction for 150 dot lines.

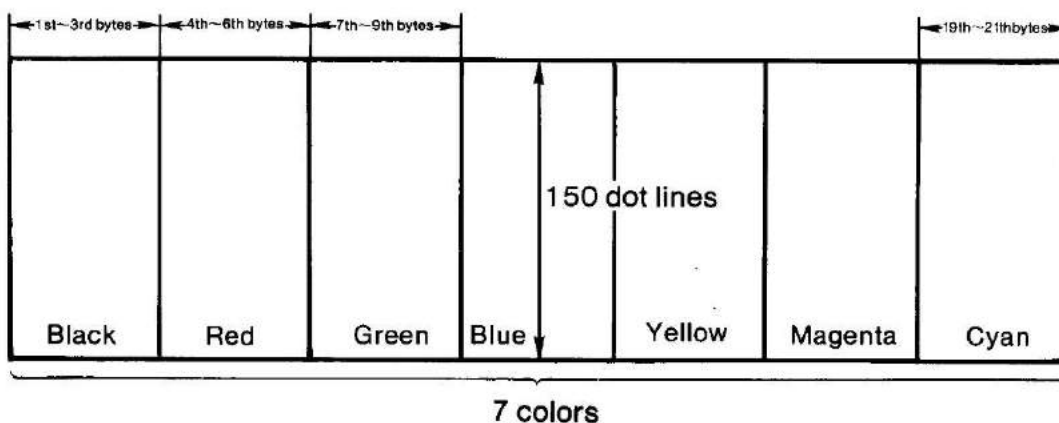

ESC "r" +n₁ +n₂**Executing Color Graphic Image Repeat****[Program]**

```

100 REM COLOR GRAPHIC IMAGE REPEAT
110 LPRINT CHR$(27);"r";CHR$(150);CHR$(21);
112 LPRINT CHR$(%H00);CHR$(%H00);CHR$(%H00);CHR$(%HFF);CHR$(%HFF);CHR$(%HFF);
114 LPRINT CHR$(%H00);CHR$(%H00);CHR$(%H00);CHR$(%H00);CHR$(%H00);CHR$(%H00);
120 LPRINT CHR$(%HFF);CHR$(%HFF);CHR$(%HFF);CHR$(%HFF);CHR$(%HFF);CHR$(%HFF);
130 LPRINT CHR$(%H00);CHR$(%H00);CHR$(%H00);
132 LPRINT CHR$(%H00);CHR$(%H00);CHR$(%H00);CHR$(%H00);CHR$(%H00);CHR$(%H00);
134 LPRINT CHR$(%HFF);CHR$(%HFF);CHR$(%HFF);CHR$(%H00);CHR$(%H00);CHR$(%H00);
140 LPRINT CHR$(%HFF);CHR$(%HFF);CHR$(%HFF);CHR$(%H00);CHR$(%H00);CHR$(%H00);
150 LPRINT CHR$(%HFF);CHR$(%HFF);CHR$(%HFF);
152 LPRINT CHR$(%H00);CHR$(%H00);CHR$(%H00);CHR$(%H00);CHR$(%H00);CHR$(%H00);
154 LPRINT CHR$(%H00);CHR$(%H00);CHR$(%H00);CHR$(%HFF);CHR$(%HFF);CHR$(%HFF);
160 LPRINT CHR$(%H00);CHR$(%H00);CHR$(%H00);CHR$(%HFF);CHR$(%HFF);CHR$(%HFF);
170 LPRINT CHR$(%HFF);CHR$(%HFF);CHR$(%HFF);
180 END

```

[Printout]

ESC "e"+n

Executing Color Graphic Image Dot Line Skip

Code: <1B>_H <65>_H <n> or <27>₁₀ <101>₁₀ <n>

BASIC Syntax: CHR\$ (&H1B); "e"; CHR\$ (n); or CHR\$ (27); "e"; CHR\$ (n);
(1 ≤ n ≤ 255)

Function: When this code is entered, the paper is fed n dot lines.

- There is no paper feed when n=0.
- After the ESC "e"+ n code has been executed, the printer is put into the previously set mode.

Example 1: Skipping by four dot lines.

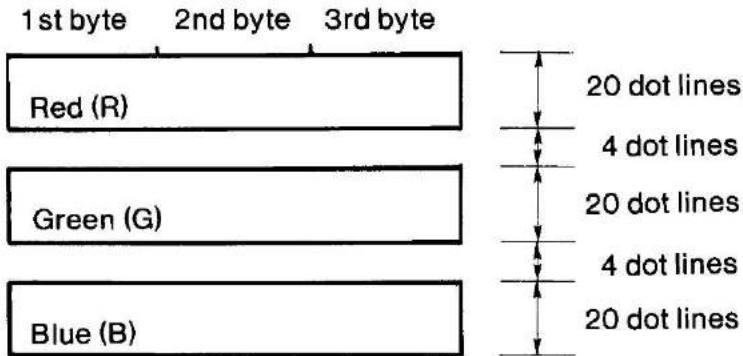

ESC "e" +n

Color Graphic Image Dot Line Skip

[Program]

```
100 REM COLOR GRAPHIC IMAGE DOT LINE SKIP
110 LPRINT CHR$(27);"r";CHR$(20);CHR$(3);
120 LPRINT CHR$(%HFF);CHR$(%HFF);CHR$(%HFF);
130 LPRINT CHR$(%H00);CHR$(%H00);CHR$(%H00);
140 LPRINT CHR$(%H00);CHR$(%H00);CHR$(%H00);
150 LPRINT CHR$(27);"e";CHR$(4);
160 LPRINT CHR$(27);"r";CHR$(20);CHR$(3);
170 LPRINT CHR$(%H00);CHR$(%H00);CHR$(%H00);
180 LPRINT CHR$(%HFF);CHR$(%HFF);CHR$(%HFF);
190 LPRINT CHR$(%H00);CHR$(%H00);CHR$(%H00);
200 LPRINT CHR$(27);"e";CHR$(4);
210 LPRINT CHR$(27);"r";CHR$(20);CHR$(3);
220 LPRINT CHR$(%H00);CHR$(%H00);CHR$(%H00);
230 LPRINT CHR$(%H00);CHR$(%H00);CHR$(%H00);
240 LPRINT CHR$(%HFF);CHR$(%HFF);CHR$(%HFF);
250 END
```

[Printout]



6. OTHER CONTROL CODES

ESC "@"

Printer Reset

Code: <1B>_H <40>_H or <27>₁₀ <64>₁₀
BASIC Syntax: CHR\$(&H1B); "@"; or CHR\$(27); "@";

Function: When this code is entered, the software modes are cancelled, and the printer is set to the modes in effect at power on.

- The contents of the print buffer are erased when this code is used.

[Program]

```
10 LPRINT CHR$(27);"@";
```

DC1

Printer Select

Code: <11>_H or <17>₁₀
BASIC Syntax: CHR\$ (&H11); or CHR\$ (17);

Function: When this code is entered, the printer is put into the **Select mode (communication possible)** and data can be received.

- The DC1 code is only used to put the printer into the Select mode from the Deselect mode set with the DC3 code.

DC3

Printer Deselect

Code: <13>_H or <19>₁₀
BASIC Syntax: CHR\$ (&H13); or CHR\$ (19);

Function: When this code is entered, the printer is put into the Deselect mode (communication not possible).

- The printer can be reset to the Select mode with the DC1 code or by pressing the  switch.
- Contents of the print buffer, colors set, etc. are not affected by this code.

[Program]

```
10 REM DC1 & DC3
20 LPRINT CHR$(17);" Printer enable DC1 1111111111"
30 LPRINT CHR$(19);" Printer disable DC3 2222222222"
40 LPRINT CHR$(17);" Printer enable DC1 3333333333"
50 END
```

[Printout]

```
Printer enable DC1 1111111111
Printer disable DC3 2222222222
Printer enable DC1 3333333333
```

APPENDICES

1. TRANSPORTATION AND STORAGE

1.1 Transportation

Be sure to pack the PJ-1080A as described below before transporting, to protect the precision ink-jet printing system.

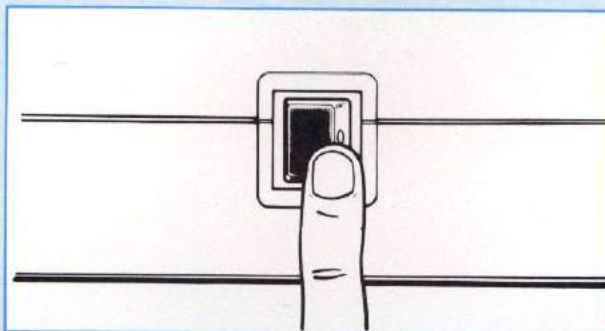

1. Turn the power switch on.

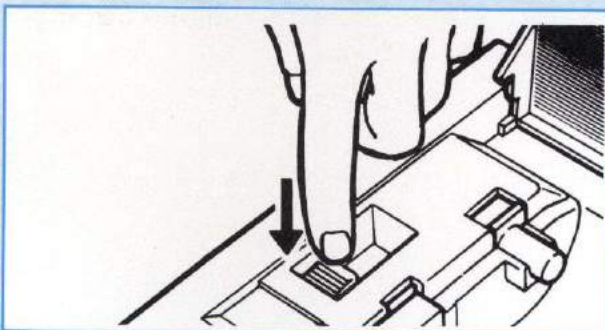

2. Lock the carriage.

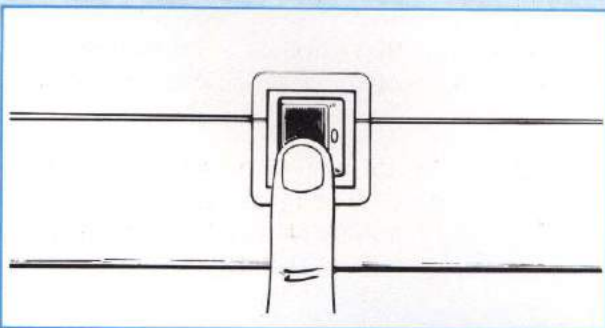

3. Turn the power switch off.

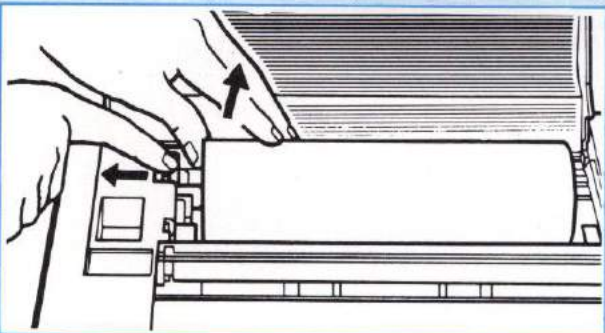

4. Remove all paper from the printer.

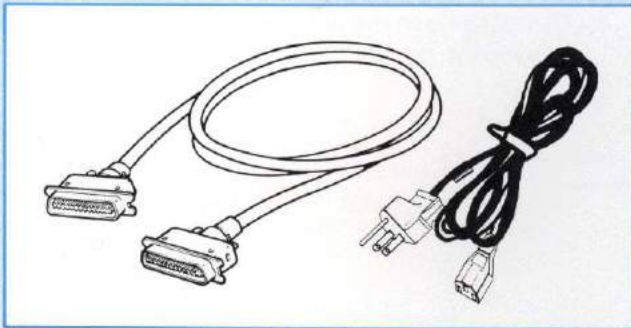

- 5.** Remove the power cord, interface cable, and ground cable.

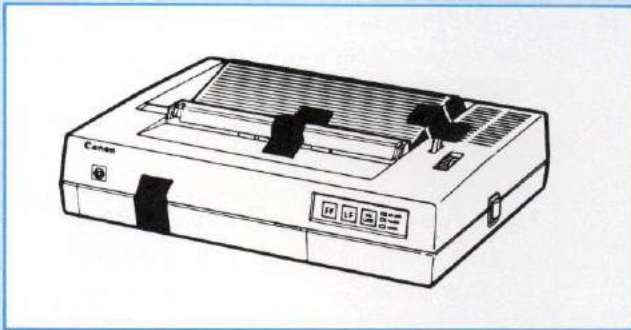

- 6.** Secure the roll paper cover and ink cartridge case cover with tape.

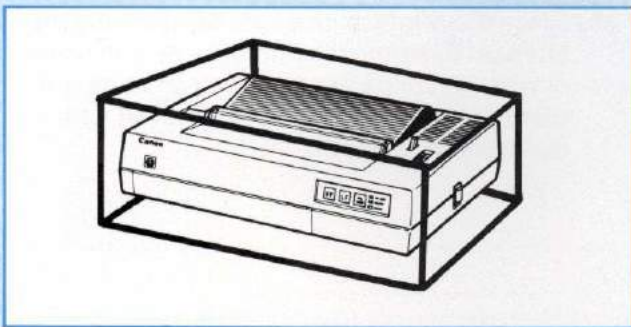

- 7.** Place the printer in its original packing box, making sure that it is well-cushioned with styrofoam or other shock-absorbent packing material.

Notes: 1. Do not remove the ink cartridges when moving the printer.
2. Be careful not to jolt the printer or expose it to vibrations during transportation.

1.2 Storage

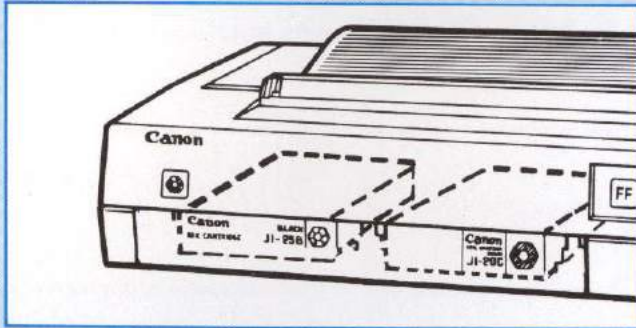

- 1.** Do not remove the ink cartridges when storing the printer.

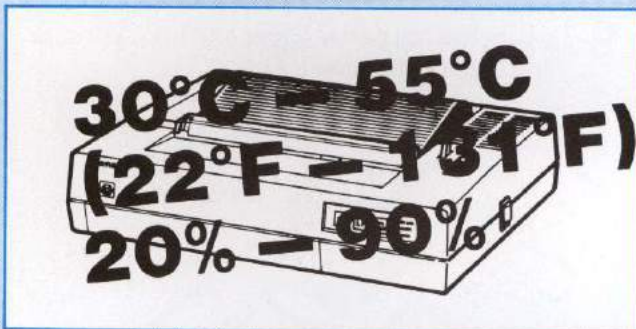

- 2.** Be sure to maintain the printer within the proper ranges of temperature and humidity during storage.



- 3.** Clean the printer with a soft, dry cloth before storage. Cleaning the printer body with water or volatile liquids like thinner or benzine will damage the cover, acrylic resin finish and electronic circuitry.

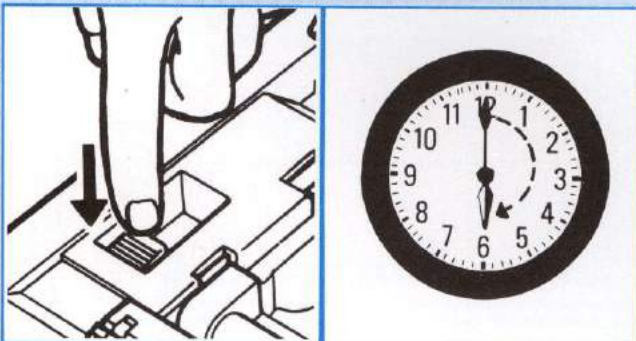

- 4.** After long periods of storage (more than six months), perform the ink supply pumping six times and then perform the printing check. If the PJ-1080A does not print, turn the power switch off and do not use the printer for six hours or more. Then repeat the ink supply pumping. If printing is still impossible, contact your Canon service representative.

2. TROUBLESHOOTING

If the printer does not operate properly, follow the troubleshooting procedure shown below.
If the problem persists, contact your Canon service representative.

(1) Printer does not print.

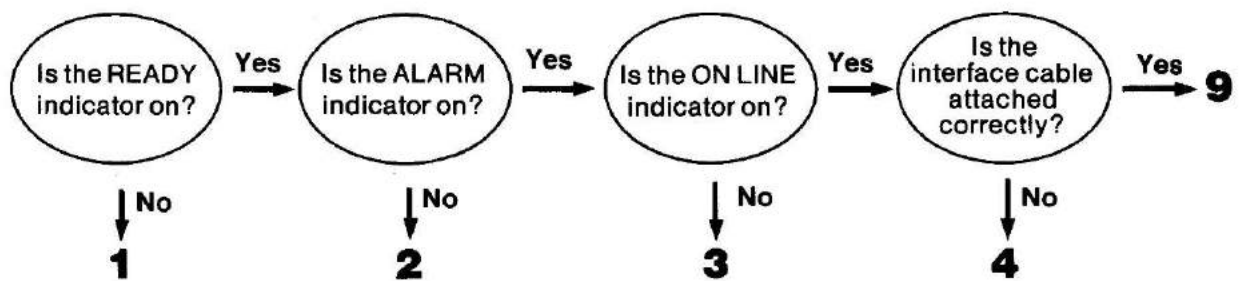

(2) Printing problems occur.

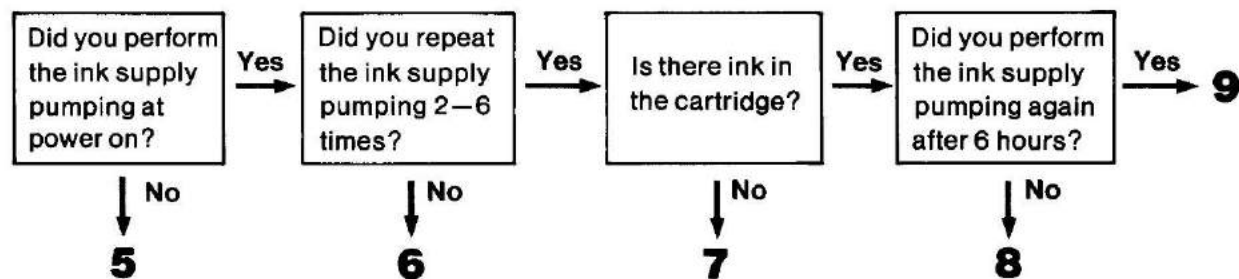

No.	Remedy
1	Check the power cord connection and power switch.
2	Clear the carriage lock and reset the paper correctly.
3	Press the ON LINE switch.
4	Check the interface cable.
5	Perform the ink supply pumping and the printing check.
6	Repeat the ink supply pumping 2-6 times.
7	Change the ink cartridge.
8	Turn the power off and do not use it for 6 hours or more. Then perform the ink supply pumping again.
9	Contact your service representative.

3. HARDWARE SPECIFICATIONS

Printing Method:	Drop-on-demand ink-jet printing
Print Head:	Piezo-electric type
Nozzle:	4 horizontally-arranged nozzles
Printing Speed:	37 characters/second(standard characters) 2630 dots/second (Image print)
Printing Direction:	Bi-directional line scanning
Printing Color	
Seven colors:	Y (yellow), M (magenta), C (cyan), Green (Y + C), Red(Y + M), Blue(M + C) and Black
Printing Characters	
Character composition:	Standard 5 × 7 dot matrix Enlarged 10 × 7 dot matrix
Character set:	Full ASCII character set (96) and special characters (64)
Character size:	1.5mm(W) × 2.7mm(H) -standard 3.0mm(W) × 2.7mm(H) -enlarged
Dot diameter:	0.25mm to 0.3mm
Maximum Characters per Line	
Standard characters:	80 characters/line
Enlarged characters:	40 Characters/line
Image Printing	
Image data:	Vertical 8-dot information
Resolution:	560 dots per line
Color Hard Copy	
Data:	Horizontal 8 dot information
Resolution:	640 dots per line
Printing Pitch	
Vertical:	4.23mm(1/6")
Horizontal:	2.12mm(1/12")
Print Buffer	
Character printing:	1 line(40 or 80 characters)
Image printing:	560 bytes × 4 colors
Color hard copy:	640 bytes × 4 colors
Interface:	8-bit parallel interface(Centronics type)
Paper	
Paper type:	Plain paper(JP-216)
Roll paper:	Maximum width 216mm(8-1/2") Maximum diameter 70mm(2-3/4") Thickness 0.095mm ± 0.005mm
Single sheet:	Maximum width 216mm(8-1/2") Length 300mm or less Thickness 0.095mm ± 0.005mm

Overhead Projection Film

A-4 size single sheet (specified only)

Ink Cartridge

Type: Dual-cartridge ink supply (specified tricolor ink cartridge JI-20C and black ink cartridge JI-25B)

Ink amount: Black-25cc; other colors-20cc each

Ink life: Approx. 3.5 million characters per color in a color cartridge
Approx. 4 million characters per black ink cartridge

Environmental Conditions

	Operation	Storage
Temperature	+10°C—+35°C (50°F—95°F)	-30°C—+55°C (22°F—131°F)
Humidity	30%—90%RH (non-condensing)	20%—90%RH (non-condensing)
Angle level	Within $\pm 5^\circ$ of horizontal	Within $\pm 5^\circ$ of horizontal

Power Source

USA/Canada	: 120V	60Hz	0.3A
UK/Europe	: 230V	50/60 Hz	25W
Australia	: 240V	50/60 Hz	25W
Others	: 110V	50/60 Hz	25W

Noise Level: Less than 50 dBA**Static Discharge Immunity:** 4KV, 200 PF (min.)**Line Disturbance:** Impulse 500V (min.) with 800ns pulse width**Physical dimensions**

Size: 400mm(W) × 295mm(L) × 114mm(H)
(15-3/4" × 11-5/8" × 4-1/4")

Weight: 5.6 kg (12.3lbs)

Subject to change without notice.

4. CHARACTER CODE TABLES

4.1 U.S.A.

Hex. No.	0	1	2	3	4	5	6	7	8	9	A	B	C	D	E	F	
0	NUL (0)		SP (16)	0 (48)	@ (64)	P (80)	Q (96)	P (112)	- (128)	1 (144)	SP (160)	- (176)	9 (192)	3 (208)	2 (224)	X (240)	0000
1		DC1 (17)	! (33)	1 (49)	A (65)	Q (81)	a (97)	q (113)	- (129)	7 (145)	7 (161)	7 (177)	7 (193)	6 (209)	5 (225)	4 (241)	0001
2		DC2 (18)	" (34)	2 (50)	B (66)	R (82)	b (98)	r (114)	- (130)	4 (146)	4 (162)	4 (178)	4 (194)	3 (210)	2 (226)	1 (242)	0010
3		DC3 (19)	# (35)	3 (51)	C (67)	S (83)	c (99)	s (115)	- (131)	5 (147)	5 (163)	5 (179)	5 (195)	4 (211)	3 (227)	2 (243)	0011
4		DC4 (20)	\$ (36)	4 (52)	D (68)	T (84)	d (100)	t (116)	- (132)	6 (148)	6 (164)	6 (180)	6 (196)	5 (212)	4 (228)	3 (244)	0100
5			% (37)	5 (53)	E (69)	U (85)	e (101)	u (117)	- (133)	8 (149)	8 (165)	8 (181)	8 (197)	7 (213)	6 (229)	5 (245)	0101
6			& (38)	6 (54)	F (70)	V (86)	f (102)	v (118)	- (134)	9 (150)	9 (166)	9 (182)	9 (198)	8 (214)	7 (230)	6 (246)	0110
7			' (39)	7 (55)	G (71)	W (87)	g (103)	w (119)	- (135)	0 (151)	0 (167)	0 (183)	0 (199)	9 (215)	8 (231)	7 (247)	0111
8		CAN (24)	((40)	8 (56)	H (72)	X (88)	h (104)	x (120)	- (136)	1 (152)	1 (168)	1 (184)	1 (200)	10 (216)	9 (232)	8 (248)	1000
9	HT (25)) (41)	9 (57)	I (73)	Y (89)	i (105)	y (121)	1 (137)	- (153)	2 (169)	2 (185)	2 (201)	2 (217)	11 (233)	10 (249)		1001
A	LF (26)	* (42)	: (58)	J (74)	Z (90)	j (106)	z (122)	1 (138)	- (154)	3 (170)	3 (186)	3 (202)	3 (218)	12 (234)	11 (250)		1010
B	VT (27)	ESC (43)	+ (59)	; (75)	K (91)	[(107)	{ (123)	1 (139)	- (155)	4 (171)	4 (187)	4 (203)	4 (219)	13 (235)	12 (251)		1011
C	FF (28)	, (44)	< (60)	L (76)	\ (92)	l (108)	1 (124)	- (140)	- (156)	5 (172)	5 (188)	5 (204)	5 (220)	14 (236)	13 (252)		1100
D	CR (29)	- (45)	= (61)	M (77)] (93)	m (109)	2 (125)	- (141)	- (157)	6 (173)	6 (189)	6 (205)	6 (221)	15 (237)	14 (253)		1101
E	SO (30)	. (46)	> (62)	N (78)	^ (94)	n (110)	3 (126)	- (142)	- (158)	7 (174)	7 (190)	7 (206)	7 (222)	16 (238)	15 (254)		1110
F		/ (31)	? (47)	O (63)	_ (79)	o (95)	4 (111)	- (127)	- (143)	8 (159)	8 (175)	8 (191)	8 (207)	17 (223)	16 (239)		1111
	0000	0001	0010	0011	0100	0101	0110	0111	1000	1001	1010	1011	1100	1101	1110	1111	Binary No.

4.2 France

Hex. No.	0	1	2	3	4	5	6	7	8	9	A	B	C	D	E	F	
0	NUL (0)		SP (32)	0 (48)	à (64)	ƒ (80)	• (96)	ƒ (112)	— (128)	⊥ (144)	SP (160)	— (176)	Ź (192)	š (208)	二 (224)	× (240)	0000
1		DC1 (17)	! (33)	1 (49)	À (65)	Œ (81)	à (97)	ŕ (113)	— (129)	⊥ (145)	• (161)	ƒ (177)	Ź (193)	š (209)	二 (225)	× (241)	0001
2		DC2 (18)	" (34)	2 (50)	B (66)	R (82)	ê (98)	ŕ (114)	— (130)	⊥ (146)	• (162)	ƒ (178)	Ź (194)	š (210)	二 (226)	× (242)	0010
3		DC3 (19)	# (35)	3 (51)	C (67)	S (83)	c (99)	š (115)	⊥ (131)	⊥ (147)	• (163)	Ź (179)	Ź (195)	š (211)	二 (227)	× (243)	0011
4		DC4 (20)	\$ (36)	4 (52)	D (68)	T (84)	d (100)	⊥ (116)	— (132)	⊥ (148)	• (164)	Ź (180)	Ź (196)	š (212)	二 (228)	× (244)	0100
5			% (37)	5 (53)	E (69)	U (85)	e (101)	u (117)	■ (133)	— (149)	• (165)	Ź (181)	Ź (197)	š (213)	二 (229)	× (245)	0101
6			& (38)	6 (54)	F (70)	V (86)	f (102)	v (118)	■ (134)	⊥ (150)	Ź (166)	Ź (182)	š (198)	š (214)	二 (230)	× (246)	0110
7			' (39)	7 (55)	G (71)	W (87)	g (103)	w (119)	■ (135)	⊥ (151)	Ź (167)	Ź (183)	š (199)	š (215)	二 (231)	× (247)	0111
8		CAN (24)	< (40)	8 (56)	H (72)	X (88)	h (104)	z (120)	⊥ (136)	⊥ (152)	Ź (168)	Ź (184)	š (200)	š (216)	二 (232)	× (248)	1000
9	HT (9)) (41)	9 (57)	I (73)	Y (89)	i (105)	y (121)	⊥ (137)	⊥ (153)	Ź (169)	Ź (185)	š (201)	š (217)	二 (233)	× (249)	1001
A	LF (10)		* (42)	; (58)	J (74)	Z (90)	j (106)	z (122)	⊥ (138)	⊥ (154)	Ź (170)	Ź (186)	š (202)	š (218)	二 (234)	× (250)	1010
B	VT (11)	ESC (27)	+ (43)	; (59)	K (75)	* (91)	k (107)	é (123)	⊥ (139)	⊥ (155)	Ź (171)	Ź (187)	š (203)	š (219)	二 (235)	× (251)	1011
C	FF (12)		, (44)	< (60)	L (76)	£ (92)	l (108)	ù (124)	⊥ (140)	⊥ (156)	Ź (172)	Ź (188)	š (204)	š (220)	二 (236)	× (252)	1100
D	CR (13)		- (45)	= (61)	M (77)	§ (93)	m (109)	è (125)	⊥ (141)	⊥ (157)	Ź (173)	Ź (189)	š (205)	š (221)	二 (237)	× (253)	1101
E	SO (14)		. (46)	> (62)	N (78)	^ (94)	n (110)	• (126)	■ (142)	⊥ (158)	Ź (174)	Ź (190)	š (206)	š (222)	二 (238)	× (254)	1110
F			/ (47)	? (63)	0 (79)	_ (95)	o (111)	• (127)	⊥ (143)	⊥ (159)	Ź (175)	Ź (191)	š (207)	š (223)	二 (239)	× (255)	1111
	0000	0001	0010	0011	0100	0101	0110	0111	1000	1001	1010	1011	1100	1101	1110	1111	Binary No.

4.3 Germany

Hex. No.	0	1	2	3	4	5	6	7	8	9	A	B	C	D	E	F	
0	NUL (0)		SP (32)	0 (48)	8 (64)	P (80)	' (96)	p (112)	- (128)	± (144)	SP (160)	- (176)	9 (192)	3 (208)	二 (224)	X (240)	0000
1		DC1 (17)	! (33)	1 (49)	À (65)	Q (81)	à (97)	q (113)	- (129)	± (145)	° (161)	7 (177)	7 (193)	6 (209)	£ (225)	円 (241)	0001
2		DC2 (18)	" (34)	2 (50)	B (66)	R (82)	b (98)	r (114)	- (130)	± (146)	° (162)	7 (178)	7 (194)	7 (210)	± (226)	年 (242)	0010
3		DC3 (19)	# (35)	3 (51)	C (67)	S (83)	c (99)	s (115)	■ (131)	† (147)	° (163)	7 (179)	7 (195)	£ (211)	± (227)	月 (243)	0011
4		DC4 (20)	\$ (36)	4 (52)	D (68)	T (84)	d (100)	t (116)	■ (132)	- (148)	、 (164)	I (180)	T (196)	P (212)	▲ (228)	日 (244)	0100
5			% (37)	5 (53)	E (69)	U (85)	e (101)	u (117)	■ (133)	- (149)	° (165)	7 (181)	7 (197)	± (213)	▲ (229)	時 (245)	0101
6			& (38)	6 (54)	F (70)	V (86)	f (102)	v (118)	■ (134)	† (150)	7 (166)	7 (182)	二 (198)	ヨ (214)	▼ (230)	分 (246)	0110
7			' (39)	7 (55)	G (71)	W (87)	g (103)	w (119)	■ (135)	† (151)	7 (167)	7 (183)	7 (199)	う (215)	▼ (231)	秒 (247)	0111
8		CAN (24)	< (40)	8 (56)	H (72)	X (88)	h (104)	x (120)	† (136)	° (152)	7 (168)	7 (184)	7 (200)	リ (216)	▲ (232)	〒 (248)	1000
9	HT (9)) (41)	9 (57)	I (73)	Y (89)	i (105)	y (121)	† (137)	° (153)	7 (169)	7 (185)	7 (201)	16 (217)	▼ (233)	市 (249)	1001
A	LF (10)		* (42)	∴ (58)	J (74)	Z (90)	j (106)	z (122)	† (138)	° (154)	7 (170)	7 (186)	7 (202)	レ (218)	◆ (234)	区 (250)	1010
B	VT (11)	ESC (27)	+ (43)	∴ (59)	K (75)	Ä (91)	k (107)	ä (123)	† (139)	° (155)	7 (171)	7 (187)	7 (203)	□ (219)	◆ (235)	町 (251)	1011
C	FF (12)		, (44)	< (60)	L (76)	ö (92)	l (108)	ö (124)	† (140)	° (156)	7 (172)	7 (188)	7 (204)	7 (220)	■ (236)	市 (252)	1100
D	CR (13)		- (45)	= (61)	M (77)	Ü (93)	m (109)	ü (125)	† (141)	° (157)	7 (173)	7 (189)	7 (205)	7 (221)	□ (237)	人 (253)	1101
E	SO (14)		. (46)	> (62)	N (78)	^ (94)	n (110)	ß (126)	† (142)	° (158)	7 (174)	7 (190)	7 (206)	° (222)	/ (238)	市 (254)	1110
F			/ (47)	? (63)	ß (79)	- (95)	o (111)		+ (127)	° (143)	7 (159)	7 (175)	7 (191)	7 (207)	7 (223)	7 (239)	1111
	0000	0001	0010	0011	0100	0101	0110	0111	1000	1001	1010	1011	1100	1101	1110	1111	Binary No.

4.4 U.K.

Hex. No.	0	1	2	3	4	5	6	7	8	9	A	B	C	D	E	F	
0	NUL (0)		SP (32)	0 (48)	@ (64)	P (80)	Q (96)	R (112)	- (128)	± (144)	SP (160)	- (176)	7 (192)	8 (208)	9 (224)	X (240)	0000
1		DC1 (17)	! (33)	1 (49)	A (65)	Q (81)	a (97)	q (113)	- (129)	τ (145)	° (161)	7 (177)	8 (193)	9 (209)	0 (225)	1 (241)	0001
2		DC2 (18)	" (34)	2 (50)	B (66)	R (82)	b (98)	r (114)	- (130)	↓ (146)	° (162)	7 (178)	8 (194)	9 (210)	0 (226)	1 (242)	0010
3		DC3 (19)	£ (35)	3 (51)	C (67)	S (83)	c (99)	s (115)	■ (131)	† (147)	° (163)	7 (179)	8 (195)	9 (211)	0 (227)	1 (243)	0011
4		DC4 (20)	\$ (36)	4 (52)	D (68)	T (84)	d (100)	t (116)	■ (132)	- (148)	° (164)	7 (180)	8 (196)	9 (212)	0 (228)	1 (244)	0100
5			% (37)	5 (53)	E (69)	U (85)	e (101)	u (117)	■ (133)	- (149)	° (165)	7 (181)	8 (197)	9 (213)	0 (229)	1 (245)	0101
6			& (38)	6 (54)	F (70)	V (86)	f (102)	v (118)	■ (134)	 (150)	° (166)	7 (182)	8 (198)	9 (214)	0 (230)	1 (246)	0110
7			' (39)	7 (55)	G (71)	W (87)	g (103)	w (119)	■ (135)	 (151)	° (167)	7 (183)	8 (199)	9 (215)	0 (231)	1 (247)	0111
8		CAN (24)	((40)	8 (56)	H (72)	X (88)	h (104)	x (120)	 (136)	° (152)	7 (168)	8 (184)	9 (200)	0 (216)	1 (232)	2 (248)	1000
9		HT (25)) (41)	9 (57)	I (73)	Y (89)	i (105)	y (121)	 (137)	° (153)	7 (169)	8 (185)	9 (201)	0 (217)	1 (233)	2 (249)	1001
A		LF (26)	* (42)	: (58)	J (74)	Z (90)	j (106)	z (122)	■ (138)	° (154)	7 (170)	8 (186)	9 (202)	0 (218)	1 (234)	2 (250)	1010
B		VT (27)	ESC (43)	+ (59)	; (75)	K (91)	[(107)	k (123)	■ (139)	° (155)	7 (171)	8 (187)	9 (203)	0 (219)	1 (235)	2 (251)	1011
C		FF (28)	, (44)	< (60)	L (76)	\ (92)	l (108)	l (124)	■ (140)	° (156)	7 (172)	8 (188)	9 (204)	0 (220)	1 (236)	2 (252)	1100
D		CR (29)	- (45)	= (61)	M (77)] (93)	m (109)] (125)	■ (141)	° (157)	7 (173)	8 (189)	9 (205)	0 (221)	1 (237)	2 (253)	1101
E		SO (30)	. (46)	> (62)	N (78)	^ (94)	n (110)	~ (126)	■ (142)	° (158)	7 (174)	8 (190)	9 (206)	0 (222)	1 (238)	2 (254)	1110
F			/ (47)	? (63)	0 (79)	_ (95)	o (111)		+ (143)	° (159)	7 (175)	8 (191)	9 (207)	0 (223)	1 (239)	2 (255)	1111
	0000	0001	0010	0011	0100	0101	0110	0111	1000	1001	1010	1011	1100	1101	1110	1111	Binary No.

4.5 Denmark

Hex. No.	0	1	2	3	4	5	6	7	8	9	A	B	C	D	E	F	
0	NUL (0)		SP (32)	0 (48)	0 (64)	P (80)	' (96)	p (112)	- (128)	⊥ (144)	SP (160)	- (176)	9 (192)	3 (208)	二 (224)	× (240)	0000
1		DC1 (17)	! (33)	1 (49)	A (65)	Q (81)	a (97)	q (113)	- (129)	τ (145)	▪ (161)	7 (177)	† (193)	6 (209)	£ (225)	円 (241)	0001
2		DC2 (18)	" (34)	2 (50)	B (66)	R (82)	b (98)	r (114)	- (130)	↓ (146)	∟ (162)	イ (178)	ツ (194)	ノ (210)	± (226)	≠ (242)	0010
3		DC3 (19)	# (35)	3 (51)	C (67)	S (83)	c (99)	s (115)	- (131)	† (147)	∟ (163)	ウ (179)	〒 (195)	モ (211)	∟ (227)	月 (243)	0011
4		DC4 (20)	\$ (36)	4 (52)	D (68)	T (84)	d (100)	t (116)	■ (132)	- (148)	∟ (164)	エ (180)	ト (196)	フ (212)	▲ (228)	日 (244)	0100
5			% (37)	5 (53)	E (69)	U (85)	e (101)	u (117)	■ (133)	- (149)	∟ (165)	オ (181)	ナ (197)	ユ (213)	▲ (229)	時 (245)	0101
6			& (38)	6 (54)	F (70)	V (86)	f (102)	v (118)	■ (134)	 (150)	ヲ (166)	カ (182)	ニ (198)	ヨ (214)	▼ (230)	☆ (246)	0110
7			' (39)	7 (55)	G (71)	W (87)	g (103)	w (119)	■ (135)	 (151)	ヲ (167)	キ (183)	ヌ (199)	ウ (215)	▼ (231)	※ (247)	0111
8		CAN (24)	< (40)	8 (56)	H (72)	X (88)	h (104)	x (120)	 (136)	∟ (152)	イ (168)	ウ (184)	キ (200)	リ (216)	▲ (232)	〒 (248)	1000
9	HT (9)) (41)	9 (57)	I (73)	Y (89)	i (105)	y (121)	 (137)	∟ (153)	ウ (169)	ケ (185)	ノ (201)	ル (217)	◆ (233)	〒 (249)	1001
A	LF (10)		* (42)	∟ (58)	J (74)	Z (90)	j (106)	z (122)	∟ (138)	∟ (154)	エ (170)	コ (186)	ル (202)	レ (218)	◆ (234)	区 (250)	1010
B	VT (11)	ESC (27)	+ (43)	∟ (59)	K (75)	E (91)	k (107)	e (123)	∟ (139)	∟ (155)	オ (171)	キ (187)	ヒ (203)	ロ (219)	◆ (235)	町 (251)	1011
C	FF (12)		, (44)	< (60)	L (76)	Ø (92)	l (108)	ø (124)	∟ (140)	∟ (156)	オ (172)	シ (188)	フ (204)	ワ (220)	● (236)	※ (252)	1100
D	CR (13)		- (45)	= (61)	M (77)	Å (93)	m (109)	å (125)	∟ (141)	∟ (157)	ユ (173)	ス (189)	∟ (205)	∟ (221)	ロ (237)	人 (253)	1101
E	SO (14)		. (46)	> (62)	N (78)	^ (94)	n (110)	ˆ (126)	∟ (142)	∟ (158)	ヨ (174)	セ (190)	ホ (206)	∟ (222)	∟ (238)	※ (254)	1110
F			/ (47)	? (63)	0 (79)	- (95)	o (111)	0 (127)	+ (143)	∟ (159)	ウ (175)	リ (191)	マ (207)	∟ (223)	∟ (239)		1111
	0000	0001	0010	0011	0100	0101	0110	0111	1000	1001	1010	1011	1100	1101	1110	1111	Binary No.

4.6 Sweden

Hex. No.	0	1	2	3	4	5	6	7	8	9	A	B	C	D	E	F	
0	NUL (0)		SP (16)	Å (32)	É (48)	Þ (64)	é (80)	þ (96)	- (112)	± (128)	SP (144)	- (160)	å (176)	ë (192)	二 (208)	× (224)	0000
1		DC1 (1)	! (17)	1 (33)	Å (49)	Q (65)	a (81)	q (97)	- (113)	± (129)	• (145)	þ (161)	ç (177)	ú (193)	£ (209)	£ (225)	0001
2		DC2 (2)	" (18)	2 (34)	B (50)	R (66)	b (82)	r (98)	- (114)	± (130)	• (146)	í (162)	ú (178)	ú (194)	± (210)	± (226)	0010
3		DC3 (3)	# (19)	3 (35)	C (51)	S (67)	c (83)	s (99)	- (115)	± (131)	• (147)	ú (163)	ú (179)	ú (195)	£ (211)	£ (227)	0011
4		DC4 (4)	\$ (20)	4 (36)	D (52)	T (68)	d (84)	t (100)	- (116)	± (132)	• (148)	í (164)	í (180)	í (196)	í (212)	í (228)	0100
5			% (21)	5 (37)	E (53)	U (69)	e (85)	u (101)	- (117)	± (133)	• (149)	å (165)	å (181)	å (197)	å (213)	å (229)	0101
6			& (22)	6 (38)	F (54)	V (70)	f (86)	v (102)	- (118)	± (134)	• (150)	å (166)	å (182)	å (198)	å (214)	å (230)	0110
7			' (23)	7 (39)	G (55)	W (71)	g (87)	w (103)	- (119)	± (135)	• (151)	å (167)	å (183)	å (199)	å (215)	å (231)	0111
8		CAN (8)	< (24)	8 (40)	H (56)	X (72)	h (88)	x (104)	- (120)	± (136)	• (152)	å (168)	å (184)	å (200)	å (216)	å (232)	1000
9		HT (9)) (25)	9 (41)	I (57)	Y (73)	i (89)	y (105)	- (121)	± (137)	• (153)	å (169)	å (185)	å (201)	å (217)	å (233)	1001
A		LF (10)	* (26)	¿ (42)	J (58)	Z (74)	j (90)	z (106)	- (122)	± (138)	• (154)	å (170)	å (186)	å (202)	å (218)	å (234)	1010
B		VT (11)	ESC (27)	+ (43)	; (59)	K (75)	å (91)	å (107)	- (123)	± (139)	• (155)	å (171)	å (187)	å (203)	å (219)	å (235)	1011
C		FF (12)	, (28)	< (44)	L (60)	ö (76)	l (92)	ö (108)	- (124)	± (140)	• (156)	å (172)	å (188)	å (204)	å (220)	å (236)	1100
D		CR (13)	- (29)	= (45)	M (61)	Å (77)	m (93)	å (109)	- (125)	± (141)	• (157)	å (173)	å (189)	å (205)	å (221)	å (237)	1101
E		SO (14)	. (30)	> (46)	N (62)	Ü (78)	n (94)	ü (110)	- (126)	± (142)	• (158)	å (174)	å (190)	å (206)	å (222)	å (238)	1110
F			/ (31)	? (47)	Ö (63)	- (79)	ö (95)		- (111)	± (127)	• (143)	å (159)	å (175)	å (191)	å (207)	å (223)	1111
	0000	0001	0010	0011	0100	0101	0110	0111	1000	1001	1010	1011	1100	1101	1110	1111	Binary No.

4.7 Italy

Hex. No.	0	1	2	3	4	5	6	7	8	9	A	B	C	D	E	F	
0	NUL (0)		SP (32)	0 (48)	à (64)	P (80)	ù (96)	þ (112)	- (128)	± (144)	SP (160)	- (176)	9 (192)	è (208)	ì (224)	× (240)	0000
1		DC1 (17)	! (33)	1 (49)	À (65)	Ò (81)	á (97)	q (113)	- (129)	± (145)	• (161)	7 (177)	ç (193)	é (209)	í (225)	¥ (241)	0001
2		DC2 (18)	" (34)	2 (50)	B (66)	R (82)	b (98)	r (114)	- (130)	± (146)	¸ (162)	ÿ (178)	¸ (194)	¸ (210)	¸ (226)	¸ (242)	0010
3		DC3 (19)	# (35)	3 (51)	C (67)	S (83)	c (99)	s (115)	■ (131)	± (147)	¸ (163)	¸ (179)	¸ (195)	¸ (211)	¸ (227)	¸ (243)	0011
4		DC4 (20)	\$ (36)	4 (52)	D (68)	T (84)	d (100)	t (116)	■ (132)	- (148)	¸ (164)	¸ (180)	¸ (196)	¸ (212)	¸ (228)	¸ (244)	0100
5			% (37)	5 (53)	E (69)	U (85)	e (101)	u (117)	■ (133)	- (149)	• (165)	¸ (181)	¸ (197)	¸ (213)	¸ (229)	¸ (245)	0101
6			& (38)	6 (54)	F (70)	U (86)	f (102)	v (118)	■ (134)	 (150)	¸ (166)	¸ (182)	¸ (198)	¸ (214)	¸ (230)	¸ (246)	0110
7			' (39)	7 (55)	G (71)	W (87)	g (103)	w (119)	■ (135)	 (151)	¸ (167)	¸ (183)	¸ (199)	¸ (215)	¸ (231)	¸ (247)	0111
8		CAN (24)	((40)	8 (56)	H (72)	X (88)	h (104)	x (120)	 (136)	¸ (152)	¸ (168)	¸ (184)	¸ (200)	¸ (216)	¸ (232)	¸ (248)	1000
9		HT (25)) (41)	9 (57)	I (73)	V (89)	i (105)	y (121)	 (137)	¸ (153)	¸ (169)	¸ (185)	¸ (201)	¸ (217)	¸ (233)	¸ (249)	1001
A		LF (26)	* (42)	: (58)	J (74)	Z (90)	j (106)	z (122)	 (138)	¸ (154)	¸ (170)	¸ (186)	¸ (202)	¸ (218)	¸ (234)	¸ (250)	1010
B		VT (27)	ESC (43)	+ (59)	; (75)	K (91)	° (107)	k (123)	■ (139)	¸ (155)	¸ (171)	¸ (187)	¸ (203)	¸ (219)	¸ (235)	¸ (251)	1011
C		FF (28)	, (44)	< (60)	L (76)	\ (92)	l (108)	ò (124)	■ (140)	¸ (156)	¸ (172)	¸ (188)	¸ (204)	¸ (220)	¸ (236)	¸ (252)	1100
D		CR (29)	- (45)	= (61)	M (77)	é (93)	m (109)	è (125)	■ (141)	¸ (157)	¸ (173)	¸ (189)	¸ (205)	¸ (221)	¸ (237)	¸ (253)	1101
E		SO (30)	. (46)	> (62)	N (78)	^ (94)	n (110)	ì (126)	■ (142)	¸ (158)	¸ (174)	¸ (190)	¸ (206)	¸ (222)	¸ (238)	¸ (254)	1110
F			/ (47)	? (63)	0 (79)	- (95)	o (111)	ó (127)	± (143)	¸ (159)	¸ (175)	¸ (191)	¸ (207)	¸ (223)	¸ (239)	¸ (255)	1111
	0000	0001	0010	0011	0100	0101	0110	0111	1000	1001	1010	1011	1100	1101	1110	1111	Binary No.

4.8 Japan

Hex. No.	0	1	2	3	4	5	6	7	8	9	A	B	C	D	E	F	
0	NUL (0)		SP (32)	0 (48)	1 (64)	2 (80)	3 (96)	4 (112)	5 (128)	6 (144)	SP (160)	7 (176)	8 (192)	9 (208)	0 (224)	1 (240)	0000
1		DC1 (17)	! (33)	1 (49)	A (65)	Q (81)	a (97)	q (113)	- (129)	τ (145)	・ (161)	ア (177)	チ (193)	ム (209)	ト (225)	円 (241)	0001
2		DC2 (18)	" (34)	2 (50)	B (66)	R (82)	b (98)	r (114)	■ (130)	↓ (146)	レ (162)	イ (178)	ウ (194)	ノ (210)	± (226)	年 (242)	0010
3		DC3 (19)	# (35)	3 (51)	C (67)	S (83)	c (99)	s (115)	■ (131)	ト (147)	J (163)	ウ (179)	チ (195)	モ (211)	↓ (227)	月 (243)	0011
4		DC4 (20)	\$ (36)	4 (52)	D (68)	T (84)	d (100)	t (116)	■ (132)	- (148)	、 (164)	イ (180)	ト (196)	ヤ (212)	▲ (228)	日 (244)	0100
5			% (37)	5 (53)	E (69)	U (85)	e (101)	u (117)	■ (133)	- (149)	・ (165)	オ (181)	ナ (197)	ユ (213)	▲ (229)	時 (245)	0101
6			& (38)	6 (54)	F (70)	U (86)	f (102)	v (118)	■ (134)	 (150)	ヲ (166)	カ (182)	ニ (198)	ヨ (214)	▼ (230)	金 (246)	0110
7			' (39)	7 (55)	G (71)	W (87)	g (103)	w (119)	■ (135)	 (151)	ッ (167)	キ (183)	ヌ (199)	ウ (215)	▼ (231)	秒 (247)	0111
8		CAN (24)	< (40)	8 (56)	H (72)	X (88)	h (104)	x (120)	 (136)	レ (152)	イ (168)	ウ (184)	ネ (200)	リ (216)	▲ (232)	円 (248)	1000
9	HT (9)) (41)	9 (57)	I (73)	V (89)	i (105)	y (121)	↓ (137)	フ (153)	ッ (169)	ケ (185)	ノ (201)	ル (217)	▼ (233)	米 (249)	1001
A	LF (10)		* (42)	: (58)	J (74)	Z (90)	j (106)	z (122)	↓ (138)	レ (154)	エ (170)	コ (186)	シ (202)	レ (218)	◆ (234)	区 (250)	1010
B	VT (11)	ESC (27)	+ (43)	; (59)	K (75)	I (91)	k (107)	l (123)	■ (139)	↓ (155)	オ (171)	サ (187)	ヒ (203)	ロ (219)	◆ (235)	町 (251)	1011
C	FF (12)		, (44)	< (60)	L (76)	Y (92)	l (108)	i (124)	■ (140)	レ (156)	サ (172)	シ (188)	フ (204)	ワ (220)	■ (236)	米 (252)	1100
D	CR (13)		- (45)	= (61)	M (77)	J (93)	m (109)	o (125)	■ (141)	、 (157)	ユ (173)	ズ (189)	ヘ (205)	コ (221)	□ (237)	人 (253)	1101
E	SO (14)		, (46)	> (62)	N (78)	^ (94)	n (110)	~ (126)	■ (142)	レ (158)	ヨ (174)	ト (190)	ホ (206)	ッ (222)	/ (238)	米 (254)	1110
F			/ (47)	? (63)	0 (79)	- (95)	o (111)		+ (127)	ノ (143)	ッ (175)	リ (191)	マ (207)	・ (223)	\ (239)		1111
	0000	0001	0010	0011	0100	0101	0110	0111	1000	1001	1010	1011	1100	1101	1110	1111	Binary No.

5. INTERNATIONAL CHARACTER CODE TABLE

HEX.	23H	24H	40H	5BH	5CH	5DH	5EH	60H	7BH	7CH	7DH	7EH
DEC.	35	36	64	91	92	93	94	96	123	124	125	126
U.S.A.	#	\$	@	[\]	^	°	()	~
FRANCE	#	\$	à	°	ç	ç	^	°	é	ù	è	"
GERMANY	#	\$	§	ä	ö	ü	^	°	ä	ö	ü	ß
U.K.	£	\$	@	[\]	^	°	()	~
DENMARK	#	\$	@	Æ	Ø	Å	^	°	#	Φ	à	~
SWEDEN	#	×	É	Ä	Ö	Å	Ü	é	ä	ö	å	ü
ITALY	#	\$	@	°	\	é	^	ù	à	ó	è	ì
JAPAN	#	\$	@	[¥]	^	°	()	~

6. APPLICATION PROGRAMS AND PRINTOUTS

Sample 1

```
100 REM GRAPH
110 PRINT "+-----+"
120 PRINT "|          VERTICAL COLOR BAR CHART          |"
130 PRINT "+-----+"
140 DIM G$(63,49),SCL$(49)
150 DIM ITEM$(15),NUM(15,1)
160 FOR I=0 TO 63
170   FOR J=0 TO 49
180     G$(I,J)=CHR$(%H37)
190   NEXT J
200 NEXT I
210 INPUT "  TITLE = ";TITLE$
220 INPUT "  NUMBER OF ITEMS ( MAX.16 ) = ";A
230 IF A>=1 AND A<=16 THEN GOTO 250
240 PRINT "          INVALID VALUE !! ":BEEP:GOTO 220
250 PRINT "|-----|"
260 B=A-1
270 FOR I=0 TO B
280   ITEM$(I)="      "
290 NEXT I
300 FOR I=0 TO B
310   INPUT "  ITEM NAME ( MAX.10 CHRS. ) = ";ITEM$(I)
320   L=LEN(ITEM$(I))
330   IF L<11 THEN GOTO 350
340   PRINT "          INVALID ITEM NAME !! ":BEEP:GOTO 310
350   INPUT "  ITEM VALUE ( MAX.99950 ) = ";NUM(I,0)
360   IF NUM(I,0)>=0 AND NUM(I,0)<=99950 THEN GOTO 380
370   PRINT "          RANGE OVER MAX.99950 !! ":BEEP:GOTO 350
380   PRINT "|-----|"
390 NEXT I
400 INPUT "  SORTING Y OR N  ";R$
410 IF R$ = "Y" THEN GOTO 440
420 IF R$ = "N" THEN GOTO 490
430 PRINT "          ENTER AGAIN !! ":BEEP:GOTO 400
440 INPUT " 1: ASCENDING OR 2: DESCENDING  ";S
450 IF S=1 OR S=2 THEN GOTO 470
460 PRINT "          ENTER AGAIN !! ":BEEP:GOTO 440
470 IF A=1 THEN GOTO 490
480 ON S GOSUB 1940,2120
490   PRINT "|-----|"
500 MAX=0
510 FOR I=0 TO B
520   IF NUM(I,0)>MAX THEN MAX=NUM(I,0)
530 NEXT I
540 I=1
550 IF MAX<=50 GOTO 610
560 K= MAX/(50*I)
570 J= INT(K)
580 IF J<1 THEN GOTO 610
590 IF K=1 THEN GOTO 610
```

```

600 I=I+1:GOTO 560
610 SCALE=50*I/10
620 LIMIT=50*I
630 UNIT=LIMIT/50
640 FOR I=0 TO 49
650   SCL$(I)="      "
660 NEXT I
670 SCL$(49)=STR$(SCALE*10)
680 SCL$(44)=STR$(SCALE*9)
690 SCL$(39)=STR$(SCALE*8)
700 SCL$(34)=STR$(SCALE*7)
710 SCL$(29)=STR$(SCALE*6)
720 SCL$(24)=STR$(SCALE*5)
730 SCL$(19)=STR$(SCALE*4)
740 SCL$(14)=STR$(SCALE*3)
750 SCL$(9)=STR$(SCALE*2)
760 SCL$(4)=STR$(SCALE*1)
770 FOR I=0 TO B
780   NUM(I,1)=INT(NUM(I,0)/UNIT+.6)-1
790 NEXT I
800 REM |-----|
810 REM |           COLOR BAR CHART PRINT           |
820 REM |-----|
830 LPRINT CHR$(27);"C";CHR$(A+5);
840 LPRINT CHR$(27);CHR$(48)
850 LPRINT "      ";
860 LPRINT CHR$(14);TITLE$
870 LPRINT
880 LPRINT " SCALE +-----";
890 LPRINT "-----+"
900 I=0
910 REM -----
920 J=I*4
930 IF NUM(I,1)<0 THEN GOTO 970
940 FOR K=0 TO NUM(I,1)
950   G$(J,K)=CHR$(&H31):G$(J+1,K)=CHR$(&H31)
960 NEXT K
970 I=I+1
980 IF I>B THEN GOTO 1490
990 REM -----
1000 J=I*4
1010 IF NUM(I,1)<0 THEN GOTO 1050
1020 FOR K=0 TO NUM(I,1)
1030   G$(J,K)=CHR$(&H32):G$(J+1,K)=CHR$(&H32)
1040 NEXT K
1050 I=I+1
1060 IF I>B THEN GOTO 1490
1070 REM -----
1080 J=I*4
1090 IF NUM(I,1)<0 THEN GOTO 1130
1100 FOR K=0 TO NUM(I,1)
1110   G$(J,K)=CHR$(&H33):G$(J+1,K)=CHR$(&H33)
1120 NEXT K
1130 I=I+1
1140 IF I>B THEN GOTO 1490
1150 REM -----
1160 J=I*4

```

```

1170 IF NUM(I,1)<0 THEN GOTO 1210
1180 FOR K=0 TO NUM(I,1)
1190   G$(J,K)=CHR$(&H34):G$(J+1,K)=CHR$(&H34)
1200 NEXT K
1210 I=I+1
1220 IF I>B THEN GOTO 1490
1230 REM -----
1240 J=I*4
1250 IF NUM(I,1)<0 THEN GOTO 1290
1260 FOR K=0 TO NUM(I,1)
1270   G$(J,K)=CHR$(&H35):G$(J+1,K)=CHR$(&H35)
1280 NEXT K
1290 I=I+1
1300 IF I>B THEN GOTO 1490
1310 REM -----
1320 J=I*4
1330 IF NUM(I,1)<0 THEN GOTO 1370
1340 FOR K=0 TO NUM(I,1)
1350   G$(J,K)=CHR$(&H36):G$(J+1,K)=CHR$(&H36)
1360 NEXT K
1370 I=I+1
1380 IF I>B THEN GOTO 1490
1390 REM -----
1400 J=I*4
1410 IF NUM(I,1)<0 THEN GOTO 1450
1420 FOR K=0 TO NUM(I,1)
1430   G$(J,K)=CHR$(&H30):G$(J+1,K)=CHR$(&H30)
1440 NEXT K
1450 I=I+1
1460 IF I>B THEN GOTO 1490
1470 REM -----
1480 GOTO 920
1490 FOR I=49 TO 0 STEP -1
1500   LPRINT USING "%   %";SCL$(I);" ";
1510   FOR J=0 TO 63
1520     LPRINT CHR$(27);CHR$(103);G$(J,I);
1530     LPRINT " ";
1540   NEXT J
1550   LPRINT CHR$(10);CHR$(13);
1560 NEXT I
1570 LPRINT "- 0 ---+-----";
1580 LPRINT "-----+"
1590 LPRINT "      |      1  2  3  4  5  6  7  8  9 10 11 12 13 ";
1600 LPRINT " 14 15 16 "
1610 LPRINT CHR$(10);CHR$(10)
1620 LPRINT CHR$(27);CHR$(50);
1630 LPRINT CHR$(27);"D";CHR$(0)
1640 LPRINT CHR$(27);"D";CHR$(8);CHR$(17);CHR$(31);CHR$(41);CHR$(50);
1650 LPRINT CHR$(64);CHR$(74);CHR$(0)
1660 LPRINT "      +-----";
1670 LPRINT "-----+"
1680 LPRINT "      | NO | ITEM NAME | VALUE  ";
1690 LPRINT "; NO | ITEM NAME | VALUE  !"
1700 LPRINT "      +-----";
1710 LPRINT "-----+"
1720 LPRINT CHR$(9);"!  1  !";CHR$(9);ITEM$(0);CHR$(9);NUM(0,0);
1730 LPRINT CHR$(9);"!  2  !";CHR$(9);ITEM$(1);CHR$(9);NUM(1,0);CHR$(9);"! "

```



```

1740 LPRINT CHR$(9);" | 3 |";CHR$(9);ITEM$(2);CHR$(9);NUM(2,0);
1750 LPRINT CHR$(9);" | 4 |";CHR$(9);ITEM$(3);CHR$(9);NUM(3,0);CHR$(9);" |"
1760 LPRINT CHR$(9);" | 5 |";CHR$(9);ITEM$(4);CHR$(9);NUM(4,0);
1770 LPRINT CHR$(9);" | 6 |";CHR$(9);ITEM$(5);CHR$(9);NUM(5,0);CHR$(9);" |"
1780 LPRINT CHR$(9);" | 7 |";CHR$(9);ITEM$(6);CHR$(9);NUM(6,0);
1790 LPRINT CHR$(9);" | 8 |";CHR$(9);ITEM$(7);CHR$(9);NUM(7,0);CHR$(9);" |"
1800 LPRINT CHR$(9);" | 9 |";CHR$(9);ITEM$(8);CHR$(9);NUM(8,0);
1810 LPRINT CHR$(9);" | 10 |";CHR$(9);ITEM$(9);CHR$(9);NUM(9,0);CHR$(9);" |"
1820 LPRINT CHR$(9);" | 11 |";CHR$(9);ITEM$(10);CHR$(9);NUM(10,0);
1830 LPRINT CHR$(9);" | 12 |";CHR$(9);ITEM$(11);CHR$(9);NUM(11,0);CHR$(9);" |"
1840 LPRINT CHR$(9);" | 13 |";CHR$(9);ITEM$(12);CHR$(9);NUM(12,0);
1850 LPRINT CHR$(9);" | 14 |";CHR$(9);ITEM$(13);CHR$(9);NUM(13,0);CHR$(9);" |"
1860 LPRINT CHR$(9);" | 15 |";CHR$(9);ITEM$(14);CHR$(9);NUM(14,0);
1870 LPRINT CHR$(9);" | 16 |";CHR$(9);ITEM$(15);CHR$(9);NUM(15,0);CHR$(9);" |"
1880 LPRINT " +-----";
1890 LPRINT "-----+"
1900 PRINT " |-----|
1910 PRINT " | PRINT END |
1920 PRINT " |-----|
1930 END
1940 REM -----
1950 REM ASCENDING SORT
1960 REM -----
1970 S=1
1980 IF S=0 THEN GOTO 2110
1990 S=0
2000 FOR I=0 TO B-1
2010 IF NUM(I,0)<=NUM(I+1,0) THEN GOTO 2090
2020 S=1
2030 W=NUM(I,0)
2040 NUM(I,0)=NUM(I+1,0)
2050 NUM(I+1,0)=W
2060 W#=ITEM$(I)
2070 ITEM$(I)=ITEM$(I+1)
2080 ITEM$(I+1)=W#
2090 NEXT I
2100 GOTO 1980
2110 RETURN
2120 REM -----
2130 REM DESCENDING SORT
2140 REM -----
2150 S=1
2160 IF S=0 THEN GOTO 2290
2170 S=0
2180 FOR I=0 TO B-1
2190 IF NUM(I,0)>=NUM(I+1,0) THEN GOTO 2270
2200 S=1
2210 W=NUM(I,0)
2220 NUM(I,0)=NUM(I+1,0)
2230 NUM(I+1,0)=W
2240 W#=ITEM$(I)
2250 ITEM$(I)=ITEM$(I+1)
2260 ITEM$(I+1)=W#
2270 NEXT I
2280 GOTO 2160
2290 RETURN

```

GRAPH-1

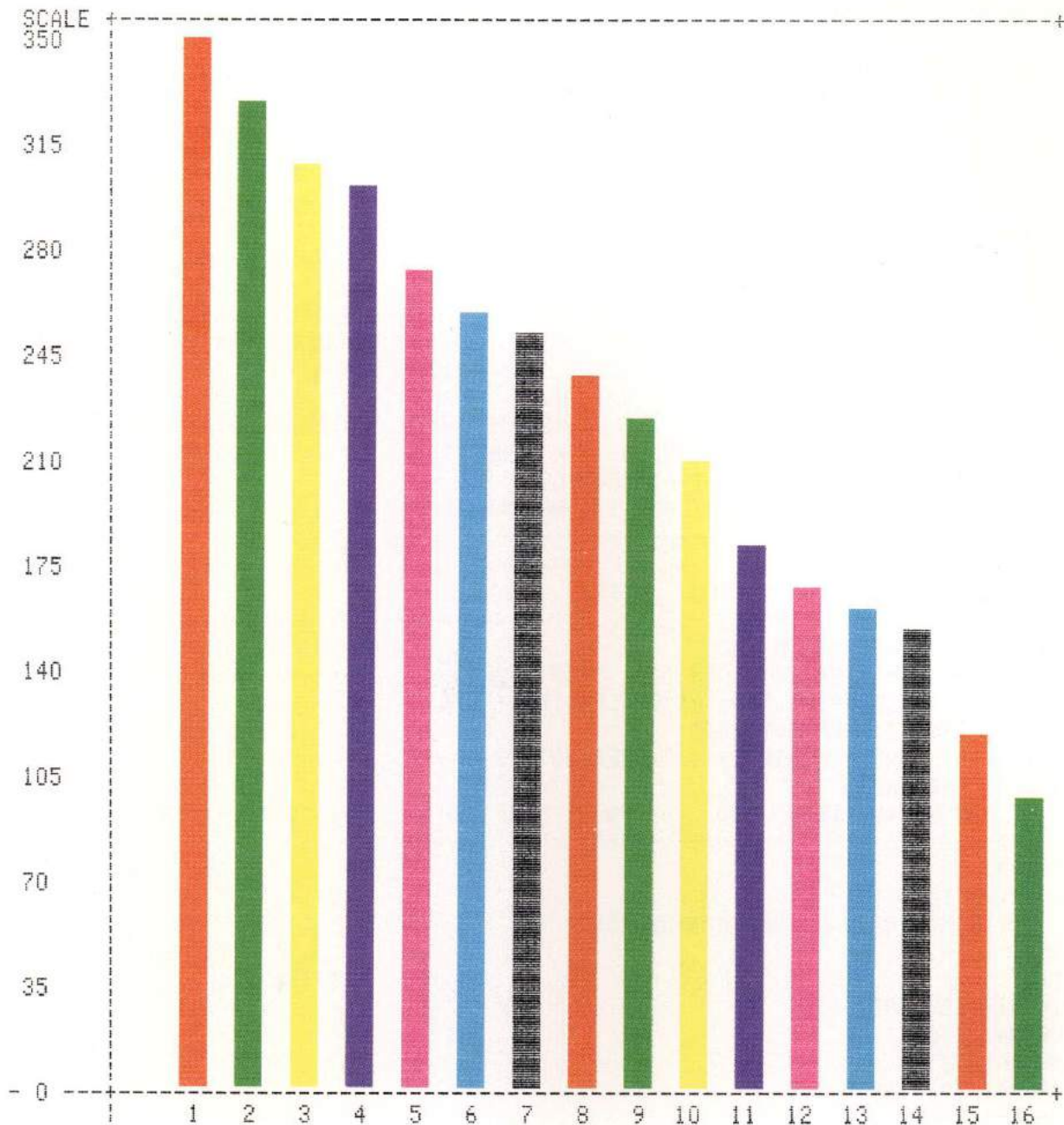

NO	ITEM NAME	VALUE	NO	ITEM NAME	VALUE
1	NAME III	350	2	NAME 000	330
3	NAME NNN	310	4	NAME CCC	300
5	NAME PPP	270	6	NAME HHH	260
7	NAME DDD	250	8	NAME JJJ	240
9	NAME MMM	220	10	NAME GGG	210
11	NAME BBB	180	12	NAME LLL	170
13	NAME FFF	160	14	NAME AAA	150
15	NAME KKK	120	16	NAME EEE	100

Sample 2

```
100 REM GRAPH
110 PRINT "+-----+"
120 PRINT "!   HORIZONTAL COLOR BAR CHART   !"
130 PRINT "+-----+"
140 INPUT "  TITLE = ";TITLE$
150 INPUT "  NUMBER OF ITEMS ( MAX.120 ) = ";A
160 IF A>=1 AND A<=120 THEN GOTO 180
170 PRINT "  INVALID VALUE !! ";BEEP:GOTO 150
180 PRINT "|-----|"
190 B=A-1
200 DIM ITEM$(B),NUM(B,1)
210 FOR I=0 TO B
220   INPUT "  ITEM NAME ( MAX.10 CHRS. ) = ";ITEM$(I)
230   L=LEN (ITEM$(I))
240   IF L>10 THEN BEEP:PRINT "  INVALID ITEM NAME !!":GOTO 220
250   INPUT "  ITEM VALUE ( MAX.999 ) = ";NUM(I,0)
260   IF NUM(I,0)>=0 AND NUM(I,0)<1000 GOTO 280
270   PRINT "  RANGE OVER MAX.999 !!";BEEP:GOTO 250
280   PRINT "|-----|"
290 NEXT I
300 INPUT "  SORTING V OR N   ";R$
310 IF R$ = "V" THEN GOTO 340
320 IF R$ = "N" THEN GOTO 390
330 BEEP: PRINT "  ENTER AGAIN !! ";GOTO 300
340 INPUT " 1: ASCENDING OR 2: DESCENDING   ";S
350 IF S=1 OR S=2 THEN GOTO 370
360 PRINT "  ENTER AGAIN !! ";BEEP:GOTO 340
370 IF A=1 THEN GOTO 390
380 ON S GOSUB 1450,1630
390 PRINT "|-----|"
400 MAX=0
410 FOR I=0 TO B
420   IF NUM(I,0)>MAX THEN MAX=NUM(I,0)
430 NEXT I
440 I=1
450 IF MAX<=50 GOTO 510
460 K= MAX/(50*I)
470 J= INT(K)
480 IF J<1 THEN GOTO 510
490 IF K=1 THEN GOTO 510
500 I=I+1:GOTO 460
510 SCALE=50*I/10
520 LIMIT=50*I
530 UNIT=LIMIT/50
540 FOR I=0 TO B
550   NUM(I,1)=INT(NUM(I,0)/UNIT+.6)
560 NEXT I
570 REM |-----|
580 REM |   COLOR BAR CHART PRINT   |
590 REM |-----|
600 LPRINT CHR$(27);"C";CHR$(A+5);
610 LPRINT CHR$(27);CHR$(50);
620 LPRINT "           ";
630 LPRINT CHR$(14);TITLE$
640 LPRINT
650 J=0
660 LPRINT CHR$(27);"D";CHR$(11);CHR$(0);
```



```

1240 IF NUM(J,1)<1 THEN GOTO 1280
1250 FOR I=1 TO NUM(J,1)
1260   LPRINT " ";
1270 NEXT I
1280 LPRINT CHR$(27);"3";CHR$(8H37);" " ;NUM(J,0)
1290 J=J+1
1300 IF J>B THEN GOTO 1320
1310 GOTO 680
1320 LPRINT "-----+-----+-----+-----+-----+-----+-----+-----+-----+-----"
1330 LPRINT CHR$(27);"D";CHR$(0);
1340 LPRINT CHR$(27);"D";CHR$(12);CHR$(15);CHR$(20);CHR$(25);CHR$(30);CHR$(35);
1350 LPRINT CHR$(40);CHR$(45);CHR$(50);CHR$(55);CHR$(60);CHR$(0);
1360 LPRINT "  SCALE  ";CHR$(9);"0";
1370 FOR I=1 TO 10
1380   J#=STR$(SCALE*I)
1390   LPRINT CHR$(9);J#;
1400 NEXT I
1410 PRINT "|-----|"
1420 PRINT "|          PRINT END          |"
1430 PRINT "|-----|"
1440 END
1450 REM -----
1460 REM          ASCENDING  SORT
1470 REM -----
1480 S=1
1490 IF S=0 THEN GOTO 1620
1500 S=0
1510 FOR I=0 TO B-1
1520   IF NUM(I,0)<=NUM(I+1,0) THEN GOTO 1600
1530   S=1
1540   W=NUM(I,0)
1550   NUM(I,0)=NUM(I+1,0)
1560   NUM(I+1,0)=W
1570   W#=ITEM$(I)
1580   ITEM$(I)=ITEM$(I+1)
1590   ITEM$(I+1)=W#
1600 NEXT I
1610 GOTO 1490
1620 RETURN
1630 REM -----
1640 REM          DESCENDING  SORT
1650 REM -----
1660 S=1
1670 IF S=0 THEN GOTO 1800
1680 S=0
1690 FOR I=0 TO B-1
1700   IF NUM(I,0)>=NUM(I+1,0) THEN GOTO 1780
1710   S=1
1720   W=NUM(I,0)
1730   NUM(I,0)=NUM(I+1,0)
1740   NUM(I+1,0)=W
1750   W#=ITEM$(I)
1760   ITEM$(I)=ITEM$(I+1)
1770   ITEM$(I+1)=W#
1780 NEXT I
1790 GOTO 1670
1800 RETURN

```

```

670 REM -----
680 LPRINT " ";ITEM$(J);CHR$(9);" ";
690 LPRINT CHR$(27);"3";CHR$(%H31);
700 IF NUM(J,1)<1 THEN GOTO 740
710 FOR I=1 TO NUM(J,1)
720   LPRINT " ";
730 NEXT I
740 LPRINT CHR$(27);"3";CHR$(%H37);" ";NUM(J,0)
750 J=J+1
760 IF J>B THEN GOTO 1320
770 REM -----
780 LPRINT " ";ITEM$(J);CHR$(9);" ";CHR$(27);"3";CHR$(%H32);
790 IF NUM(J,1)<1 THEN GOTO 830
800 FOR I=1 TO NUM(J,1)
810   LPRINT " ";
820 NEXT I
830 LPRINT CHR$(27);"3";CHR$(%H37);" ";NUM(J,0)
840 J=J+1
850 IF J>B THEN GOTO 1320
860 REM -----
870 LPRINT " ";ITEM$(J);CHR$(9);" ";CHR$(27);"3";CHR$(%H33);
880 IF NUM(J,1)<1 THEN GOTO 920
890 FOR I=1 TO NUM(J,1)
900   LPRINT " ";
910 NEXT I
920 LPRINT CHR$(27);"3";CHR$(%H37);" ";NUM(J,0)
930 J=J+1
940 IF J>B THEN GOTO 1320
950 REM -----
960 LPRINT " ";ITEM$(J);CHR$(9);" ";CHR$(27);"3";CHR$(%H34);
970 IF NUM(J,1)<1 THEN GOTO 1010
980 FOR I=1 TO NUM(J,1)
990   LPRINT " ";
1000 NEXT I
1010 LPRINT CHR$(27);"3";CHR$(%H37);" ";NUM(J,0)
1020 J=J+1
1030 IF J>B THEN GOTO 1320
1040 REM -----
1050 LPRINT " ";ITEM$(J);CHR$(9);" ";CHR$(27);"3";CHR$(%H35);
1060 IF NUM(J,1)<1 THEN GOTO 1100
1070 FOR I=1 TO NUM(J,1)
1080   LPRINT " ";
1090 NEXT I
1100 LPRINT CHR$(27);"3";CHR$(%H37);" ";NUM(J,0)
1110 J=J+1
1120 IF J>B THEN GOTO 1320
1130 REM -----
1140 LPRINT " ";ITEM$(J);CHR$(9);" ";CHR$(27);"3";CHR$(%H36);
1150 IF NUM(J,1)<1 THEN GOTO 1190
1160 FOR I=1 TO NUM(J,1)
1170   LPRINT " ";
1180 NEXT I
1190 LPRINT CHR$(27);"3";CHR$(%H37);" ";NUM(J,0)
1200 J=J+1
1210 IF J>B THEN GOTO 1320
1220 REM -----
1230 LPRINT " ";ITEM$(J);CHR$(9);" ";CHR$(27);"3";CHR$(%H30);

```

GRAPH-2

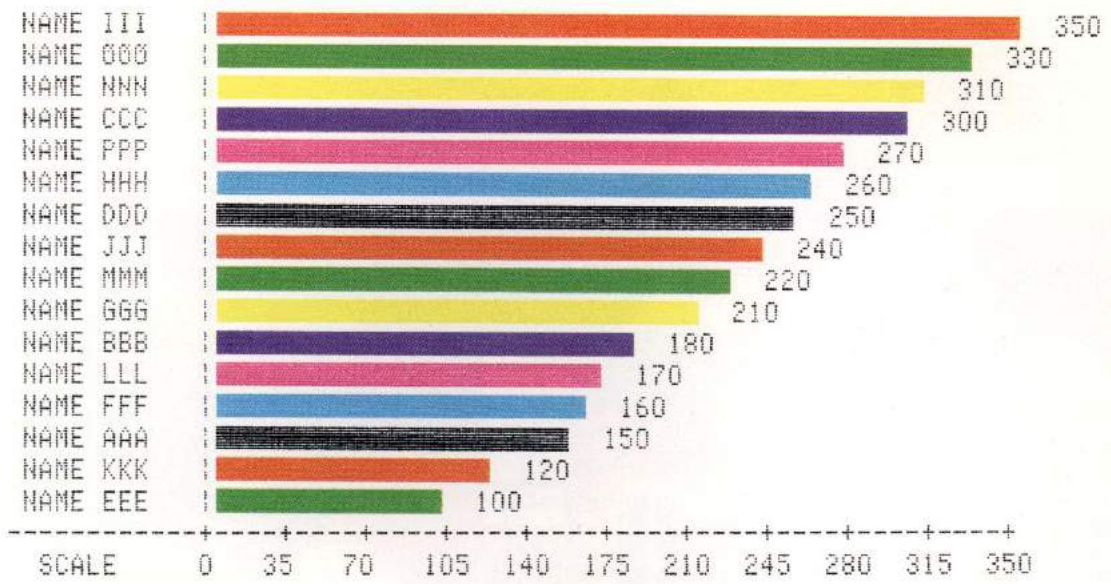

Sample 3

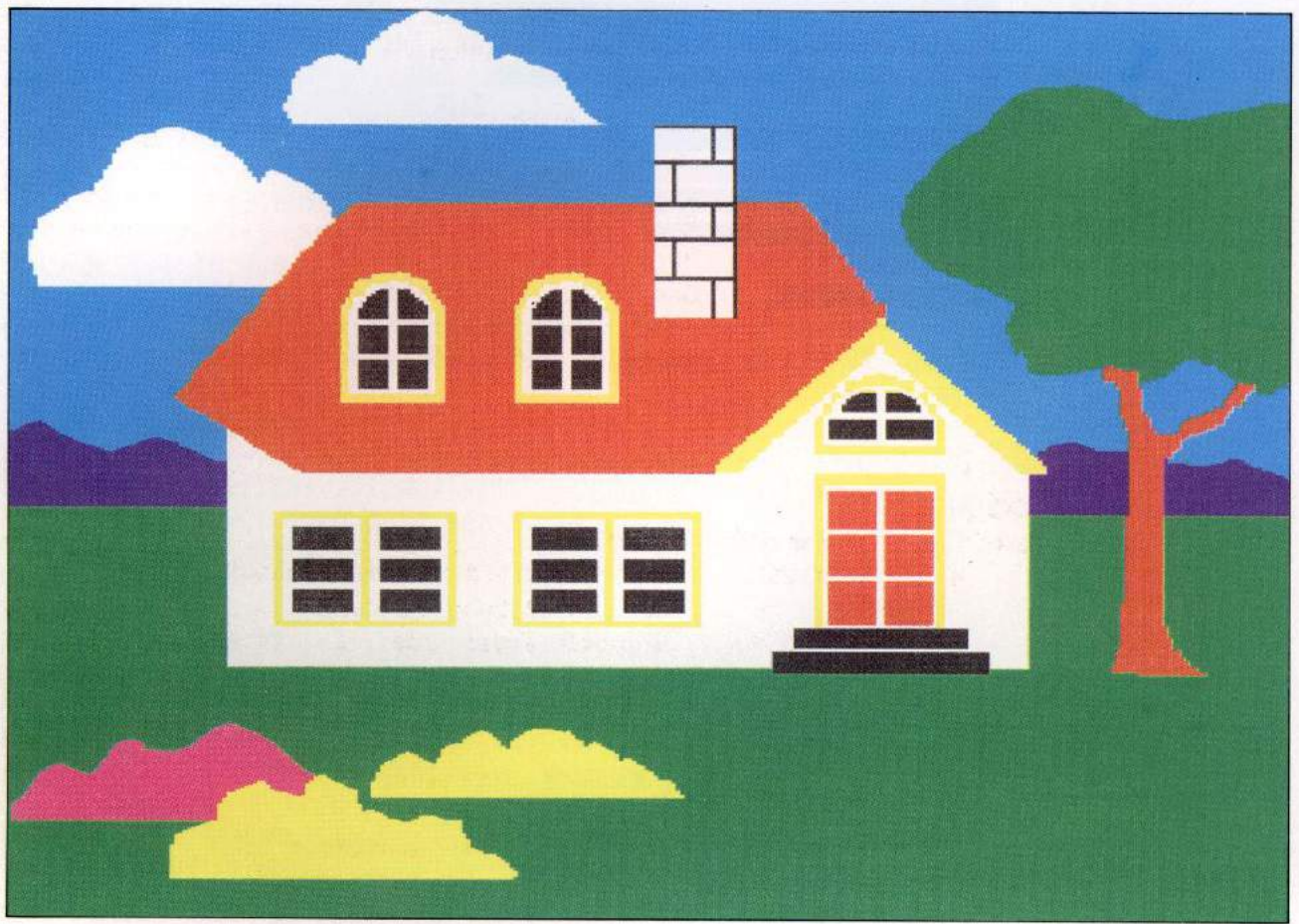

7. CONTROL CODE LIST

7.1 Basic Code

Hex. code	Dec. code	Mnemonic	Function	Page
09	9	HT	Horizontal tab execution	51
0A	10	LF	Line feed	38
0B	11	VT	Vertical tab execution	54
0C	12	FF	Form feed	45
0D	13	CR	Carriage return	36
0E	14	SO	Setting Enlarged mode with automatic self-cancellation	65
11	17	DC1	Printer select	94
13	19	DC3	Printer deselect	95
14	20	DC4	Cancelling Enlarged mode with automatic self-cancellation	69
18	24	CAN	Cancelling	37

7.2 Expanded Codes

Hex. code	Dec. code	Mnemonic	Function	Page
1B 0E	27 14	ESC SO	Setting Enlarged mode with automatic self-cancellation	67
1B 21	27 33	ESC"!"+n	Setting Enlarged mode	71
1B 2A	27 42	ESC"""+m+n ₁ +n ₂	Setting Graphic Image mode	82
1B 2D	27 45	ESC"-"	Setting Underlined Print mode	76
1B 30	27 48	ESC"0"	1/8-inch line spacing	39
1B 32	27 50	ESC2	1/6-inch Line Spacing	40
1B 40	27 64	ESC"@"	Resetting printer	93
1B 42	27 66	ESC"B"+n ₁ +n ₂ +...+n _k +0	Vertical tab setting	53
1B 43	27 67	ESC"C"+0+n	Page format by inches	41
		ESC"C"+n	Page format by lines	43
1B 44	27 68	ESC"D"+n ₁ +n ₂ +...+n _k +0	Setting horizontal tab	50
1B 47	27 71	ESC"G"	Setting Bold mode	72
1B 48	27 72	ESC"H"	Cancelling Bold mode	75
1B 4B	27 75	ESC"K"+n ₁ +n ₂	Setting Graphic Image mode	78
1B 4E	27 78	ESC"N"+n	Setting perforation skip	46
1B 4F	27 79	ESC"O"	Cancelling perforation skip	49
1B 56	27 86	ESC"V"+n	Setting Character color	57
1B 57	27 87	ESC"W"+n	Setting Enlarged mode	70
1B 58	27 88	ESC"X"+n	Setting Color Graphic Image mode	84
1B 64	27 100	ESC"d"+n	Setting Solorized mode	63
1B 65	27 101	ESC"e"+n	Executing color graphic image dot line skip	91
1B 67	27 103	ESC"g"+n	Setting Background color	59
1B 72	27 114	ESC"r"+n ₁ +n ₂	Executing color graphic image repeat	89

Canon CANON INC.

7-1, Nishi-shinjuku 2-chome, Shinjuku-ku, Tokyo 160, Japan
P.O. Box 5050, Shinjuku Dai-ichi Seimei Building, Tokyo 160, Japan

CANON U.S.A., INC.

HEAD OFFICE One Canon Plaza, Lake Success, N.Y. 11042, U.S.A.

CANON EUROPA N.V.

P.O. Box 7907, 1008 AC Amsterdam, The Netherlands

CANON FRANCE S.A.

Centre D'Affaires Paris-Nord, Immeuble Ampère 5, 93151 Le Blanc-Mesnil, Cedex, France

CANON U.K. LTD.

Waddon House, Stafford Road, Croydon CR9 4DD, England